

**MODEL 7200
CAPACITANCE METER
INSTRUCTION MANUAL**

BOONTON

BOONTON ELECTRONICS CORPORATION ■ 25 EASTMANS ROAD ■ PARSIPPANY, NEW JERSEY 07054-0465

TELEPHONE: (973) 386-9696 ■ FAX: (973) 386-9191 E-MAIL: boonton@boonton.com

SAFETY SUMMARY

The following general safety precautions must be observed during all phases of operation and maintenance of this instrument. Failure to comply with these precautions or with specific warnings elsewhere in this manual violates safety standards of design, manufacture, and intended use of the instruments. Boonton Electronics Corporation assumes no liability for the customer's failure to comply with these requirements.

THE INSTRUMENT MUST BE GROUNDED.

To minimize shock hazard the instrument chassis and cabinet must be connected to an electrical ground. The instrument is equipped with a three conductor, three prong AC power cable. The power cable must either be plugged into an approved three-contact electrical outlet or used with a three-contact to a two-contact adapter with the (green) grounding wire firmly connected to an electrical ground at the power outlet.

DO NOT OPERATE THE INSTRUMENT IN AN EXPLOSIVE ATMOSPHERE.

Do not operate the instrument in the presence of flammable gases or fumes.

KEEP AWAY FROM LIVE CIRCUITS.

Operating personnel must not remove instrument covers. Component replacement and internal adjustments must be made by qualified maintenance personnel. Do not replace components with the power cable connected. Under certain conditions dangerous voltages may exist even though the power cable was removed; therefore, always disconnect power and discharge circuits before touching them.

DO NOT SERVICE OR ADJUST ALONE.

Do not attempt internal service or adjustment unless another person, capable of rendering first aid and resuscitation, is present.

DO NOT SUBSTITUTE PARTS OR MODIFY INSTRUMENT.

Do not install substitute parts or perform any unauthorized modification of the instrument. Return the instrument to Boonton Electronics for repair to ensure that the safety features are maintained.

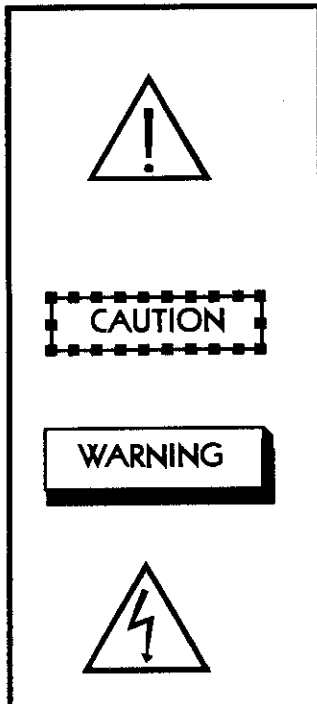

This safety requirement symbol has been adopted by the International Electrotechnical Commission, Document 66 (Central Office) 3, Paragraph 5.3, which directs that an instrument be so labeled if, for the correct use of the instrument, it is necessary to refer to the instruction manual. In this case it is recommended that reference be made to the instruction manual when connecting the instrument to the proper power source. Verify that the correct fuse is installed for the power available, and that the switch on the rear panel is set to the applicable operating voltage.

The CAUTION sign denotes a hazard. It calls attention to an operation procedure, practice, or the like, which, if not correctly performed or adhered to, could result in damage to or destruction of part or all of the equipment. Do not proceed beyond a CAUTION sign until the indicated conditions are fully understood and met.

The WARNING sign denotes a hazard. It calls attention to an operation procedure, practice, or the like, which, if not correctly performed or adhered to, could result in injury or loss of life. Do not proceed beyond a warning sign until the indicated conditions are fully understood and met.

This SAFETY REQUIREMENT symbol has been adopted by the International Electrotechnical Commission, document 66 (Central Office)3, Paragraph 5.3 which indicates hazardous voltage may be present in the vicinity of the marking.

IMPORTANT NOTICE

DECEMBER 1, 1995

INSTRUCTION MANUAL-ADDENDUM: MODEL 7200

Instruction manual addenda are issued to adapt the manual to changes and improvements made after this printing. Please review the following text and retain with your manual for future reference. These changes will be applied in the next printing of the manual.

Thank you for selecting BOONTON ELECTRONICS for your Test and Measurement needs.

Page 1-3 Table 1-1 Supplemental Information

Add the following:

Ventilation Requirements:

1 1/2 inch clearance after installation, top, side, and rear

Temperature:

Operating: 10 to 40 degrees C

Non-Operating: -40 to 75 degrees C

Altitude:

Operating: 10,000 FT

Non-Operating: 15,000 FT

Humidity:

95% (non-condensing)

Battery Type:

Refer to page 6-2

CE MARK: Declares Conformity to European Community (EC) Council Directives :

89/336/EEC//93/68/EEC, 73/23/EEC//93/68/EEC & Standards : EN55011,

EN50082-1, EN61010-1

Page 2-1 Line Voltage Select Chart

Change 3/8 ATD & 0.2 ATD to 3/8A T & 0.2 A T

IMPORTANT NOTICE

MARCH 18, 1996

INSTRUCTION MANUAL-ADDENDUM: MODEL 7200

Instruction manual addenda are issued to adapt the manual to changes and improvements made after this printing. Please review the following text and retain with your manual for future reference. These changes will be applied in the next printing of the manual.

Thank you for selecting BOONTON ELECTRONICS for your Test and Measurement needs.

Page 7-23, AMPLIFIER SCHEMATIC
CHANGE Q5 TO 2N4416

Page 6-3, AMPLIFIER REPLACEMENT PARTS
CHANGE Q5 TO TRANS FET 2N4416 N-CHANNEL, BEC P/N 528072000

IMPORTANT NOTICE

MARCH 18, 1996

INSTRUCTION MANUAL-ADDENDUM: MODEL 7200

Instruction manual addenda are issued to adapt the manual to changes and improvements made after this printing. Please review the following text and retain with your manual for future reference. These changes will be applied in the next printing of the manual.

Thank you for selecting BOONTON ELECTRONICS for your Test and Measurement needs.

Page 7-23, AMPLIFIER SCHEMATIC
CHANGE Q5 TO 2N4416

Page 6-3, AMPLIFIER REPLACEMENT PARTS
CHANGE Q5 TO TRANS FET 2N4416 N-CHANNEL, BEC P/N 528072000

IMPORTANT NOTICE

April 2, 2001

OPERATION AND MAINTENANCE MANUAL-ADDENDUM: MODEL 7200

Operation and Instruction manual addenda are issued to adapt the manual to changes and improvements made after this printing. Please review the following text and retain with your manual for future reference. These changes will be applied in the next printing of the manual.

Thank you for selecting BOONTON ELECTRONICS for your Test and Measurement needs.

Page 1-1 "Programmable Bias and Test Level", paragraph 1-4.c.

CHANGE " ± 200 volts" TO " ± 60 volts".

CHANGE " ± 100 volts" TO " ± 60 volts".

Page 1-2 "Table 1-1. Performance Specifications."

"External Bias Measurement"

CHANGE "Range: ± 200 volts" TO "Range: ± 60 volts".

Page 1-3 "Table 1-1. Performance Specifications Continued."

"Internal Bias Source"

CHANGE "Range: $\pm 100V$ " TO "Range: $\pm 60V$ ".

"Rear Panel Connectors External Bias Input:"

CHANGE " ± 200 V maximum" TO " ± 60 V maximum".

Page 2-1 "External Bias", paragraph 2-14.

CHANGE " ± 200 volts" TO " ± 60 volts".

Page 2-3 "PRELIMINARY CHECK.", paragraph 2-18.f.

CHANGE "200 volts" TO "60 volts".

Page 3-10 "Rear Panel Connectors.", paragraph 3-30.

CHANGE in two places "200 volts" TO "60 volts".

Page 3-11 "Applying External Bias.", paragraph 3-38 and paragraph 3-38.d. NOTE.

CHANGE "200 volts" TO "60 volts".

Page 3-11 "Applying Pulse Bias.", paragraph 3-39 line 5.

CHANGE TEXT "cuase" TO "cause".

Page 3-13 "Applying Internal Bias.", paragraph 3-40.

CHANGE " ± 100 volts" TO " ± 60 volts".

Page 3-14 "Table 3-2. Special Function Codes.", paragraph 3-40.

"Internal Bias Ranging Functions:"

CHANGE "hold 100.00 V range" TO "hold 60.00 V range".

Page 3-16 "Selecting Internal Bias Ranges.", paragraph 3-54.
CHANGE "100 volt" TO "60 volt".

Page 3-18 "Table 3-4. SETUP Mode Selections."
"Sweep Parameter Functions"
CHANGE in three places "100 volts" TO "60 volts".

Page 3-20 "Table 3-6. Error Codes."
FOR ERROR CODE 60 CHANGE "100 V range" TO "60 V range".

Page 3-21 "Table 3-7. IEEE-488 Bus Mnemonics."
"Functions With Numerical Arguments:"
CHANGE "BI Internal Bias (-100.00 to +100.00 V)"
TO "BI Internal Bias (-60.00 to +60.00 V)"

CHANGE "XL Bias Start (-100.00 to +100.00 V)"
TO "XL Bias Start (-60.00 to +60.00 V)"

CHANGE "XR Bias Stop (-100.00 to +100.00 V)"
TO "XR Bias Stop (-60.00 to +60.00 V)"

CHANGE "XS Bias Step (0 to 100.00 V)"
TO "XS Bias Step (0 to 60.00 V)"

Page 4-4 "D.C. Bias Circuitry.", paragraph 4-14. line 5.
CHANGE " ± 100 volts" TO " ± 60 volts".

Page 5-2 "Table 5-1. Recommended test Equipment and Tools."
CHANGE THE CRITICAL SPECIFICATIONS FOR THE POWER SUPPLY
FROM "Level Range: 0 to 200VDC" TO "Level Range: 0 to 60VDC".

Page 5-11 "Table 5-9. Internal Bias Accuracy Test."
DELETE "Internal Bias Setting +100.00 V".
DELETE "Internal Bias Setting -100.00 V".

Page 5-12 "Table 5-10. External Bias Accuracy Test."
DELETE "Power Supply Setting +200.00 V".
DELETE "Power Supply Setting -200.00 V".

Page 5-13 "Internal Bias Calibration.", paragraph 5-35.7
CHANGE "100 volt" TO "60 volt".

Page 6-2 Parts List

CHANGE "07231000B PWA '7200' CONTROL (A3)"
TO "07231000C PWA '7200' CONTROL (A3)".

Page 6-3 Parts List

CHANGE "07231000B PWA '7200' CONTROL (A3) CONTINUED"
TO "07231000C PWA '7200' CONTROL (A3) CONTINUED".

Page 6-3 Parts List "07231000B PWA '7200' CONTROL (A3) CONTINUED"
CHANGE MANUF. PART NUMBER AND BEC PART NUMBER
FOR U10 FROM "53459000A" TO "53488600A".

Page 6-3 Parts List "07231000B PWA '7200' CONTROL (A3) CONTINUED"
CHANGE MANUF. PART NUMBER AND BEC PART NUMBER
FOR U11 FROM "53459100A" TO "53488700A".

Page 6-4 Parts List

CHANGE "07231000B PWA '7200' CONTROL (A3) CONTINUED"
TO "07231000C PWA '7200' CONTROL (A3) CONTINUED".

Table of Contents

Paragraph	Page
SECTION I - GENERAL INFORMATION	
1-1. INTRODUCTION.	1-1
1-3. DESCRIPTION.	1-1
1-5. ACCESSORIES.	1-2
1-7. OPTIONS.	1-2
1-9. SPECIFICATIONS.	1-2
SECTION II - INSTALLATION	
2-1. INTRODUCTION.	2-1
2-3. UNPACKING.	2-1
2-5. MOUNTING.	2-1
2-7. POWER REQUIREMENTS.	2-1
2-10. FRONT PANEL CONNECTIONS.	2-1
2-11. Test Terminals.	2-1
2-12. Differential Terminals.	2-1
2-13. REAR PANEL CONNECTIONS.	2-1
2-14. External Bias.	2-1
2-15. IEEE-488 Bus Interface.	2-1
2-16. Analog Outputs.	2-2
2-17. PRELIMINARY CHECK.	2-2
SECTION III - OPERATION	
3-1. INTRODUCTION.	3-1
3-3. CONTROLS, INDICATORS, AND CONNECTORS.	3-1
3-6. Instrument Displays and Indicators.	3-1
3-9. Measurement Function Keys.	3-2
3-10. LOSS Function Keys.	3-2
3-11. CAPACITANCE Function Keys.	3-4
3-12. ZERO Key.	3-4
3-13. BIAS Function Keys.	3-4
3-14. BIAS ON, INT And EXT Keys.	3-4
3-15. SETUP Key.	3-4
3-17. SWEEP Key.	3-4
3-18. PLOT Key.	3-4
3-19. Miscellaneous Function Keys.	3-4
3-20. SPCL Key.	3-4
3-21. PRGM, STORE And RECALL Keys.	3-5
3-22. LCL/INIT Key.	3-6
3-23. SHIFT/SCROLL Key.	3-6
3-24. DATA ENTRY Keypad.	3-7

Paragraph	Page
3-25. The CLR Key.	3-7
3-26. Front Panel Connectors.	3-8
3-27. Rear Panel Connectors.	3-8
3-32. LOCAL OPERATION.	3-10
3-33. Applying AC Power.	3-10
3-34. Selecting Measurement Modes.	3-11
3-36. Zeroing the Instrument.	3-11
3-37. Extending Instrument Measurement Range.	3-11
3-38. Applying External Bias.	3-11
3-39. Applying Pulse Bias.	3-13
3-40. Applying Internal Bias.	3-13
3-41. Remote Measurements And Cable Effects.	3-13
3-44. Programming Special Functions.	3-13
3-45. Selecting Test Level.	3-14
3-46. Selecting Capacitance Standard.	3-14
3-47. Selecting Conductance Standard.	3-15
3-48. Selecting Capacitance High and Low Limits.	3-15
3-49. Selecting IEEE-488 Bus Address.	3-15
3-50. Selecting End-of-string Character.	3-15
3-51. Selecting Capacitance Uncertainty Display.	3-15
3-52. Selecting Conductance Uncertainty Display.	3-16
3-53. Selecting Measurement Ranges.	3-16
3-54. Selecting Internal Bias Ranges.	3-16
3-55. Selecting Measurement Filter Lengths.	3-16
3-56. Selecting SRQ Interrupt Modes.	3-17
3-57. Selecting Automatic Calibration Modes.	3-17
3-58. Selecting Temperature Display Modes.	3-17
3-59. Selecting Memory Initialization Functions.	3-17
3-60. Store And Recall Program Operation.	3-17
3-61. Using The SETUP Mode.	3-19
3-64. Setting The Option/Test Switch.	3-20
3-65. Error Messages.	3-20
3-66. IEEE-488 BUS OPERATION.	3-20
3-67. General.	3-20
3-68. Entering Remote Mode.	3-20
3-69. Returning To Local Mode.	3-20
3-70. Talk Operation.	3-22
3-71. Program Function Mnemonics.	3-22
3-72. Triggered Operation.	3-22
3-73. Using Service Request.	3-22
3-74. Bus Command Responses.	3-22
3-75. Number formatting.	3-23
3-76. Data String Syntax.	3-23
3-77. Selecting Menu Modes Using The Bus.	3-23
3-78. Data String Examples.	3-23

SECTION IV - THEORY OF OPERATION

4-1. General Description.	4-1
4-3. Detailed Description.	4-2
4-4. 1 MHz Oscillator Circuitry.	4-2
4-5. Front Panel Test Terminals.	4-2

Paragraph	Page
4-7. Input Ranging Circuitry.	4-2
4-8. Input Amplifier Circuitry.	4-2
4-10. Phase Sensitive Detection Circuitry.	4-2
4-12. Measurement Zeroing Circuitry.	4-3
4-14. D.C. Bias Circuitry.	4-3
4-15. Digital Control Circuitry.	4-4
4-27. Measurement Averaging.	4-4
4-28. Internal Temperature Measurement Circuitry.	4-5
4-29. Front Panel Keyboard Circuitry.	4-5
4-30. Front Panel Display Circuitry.	4-5
4-31. Power Supply Circuitry.	4-5
4-32. Rear Panel Analog Output Circuitry.	4-5

SECTION V - MAINTENANCE

5-1. INTRODUCTION.	5-1
5-3. Required Equipment.	5-1
5-4. Cleaning Procedure.	5-1
5-5. Removal of Covers.	5-1
5-6. Visual Checks.	5-1
5-7. Component Removal.	5-1
5-8. Removal and Replacement of EPROMs.	5-1
5-9. PERFORMANCE VERIFICATION	5-3
5-11. Temperature Influence.	5-3
5-15. Test Level Functional Check.	5-4
5-16. Capacitance and Conductance Test Limits.	5-5
5-17. Capacitance (Cp) Performance Test.	5-5
5-19. Conductance (G) Performance Test.	5-5
5-21. Analog Output Linearity Performance Test.	5-6
5-23. Capacitance Analog Output Linearity Test.	5-6
5-24. Conductance Analog Output Linearity Test.	5-7
5-25. Internal Bias Performance Test.	5-7
5-27. External Bias Performance Test.	5-7
5-29. Input Loading Performance Test.	5-8
5-31. SOFTWARE CALIBRATION	5-12
5-34. External Bias Calibration.	5-12
5-35. Internal Bias Calibration.	5-12
5-36. Detector Offset Calibration.	5-13
5-37. Capacitance Full-Scale Calibration.	5-13
5-39. ADJUSTMENTS	5-14
5-42. Calibration Memory Initialization.	5-14
5-44. Amplifier Board adjustments.	5-15
5-45. 2 pF Range Loading Adjustment, A5A3L2.	5-15
5-46. 20 pF Range Loading Adjustment, A5A3L4.	5-15
5-47. 200 pF Range Loading Adjustment, A5A3L5.	5-16
5-48. Phase Detector Board Adjustments.	5-16
5-49. Nominal Phase Adjustment, A5A2R26.	5-16
5-50. Capacitance Full-scale Adjustment, A5A2R33.	5-16
5-51. Minor Phase Adjustment, A5A2R45.	5-17
5-52. Conductance Full-scale Adjustment, A5A2R30.	5-17
5-54. TROUBLESHOOTING	5-17
5-58. Trouble Localization.	5-18

5-59. Self Diagnostic Routines.	5-18
5-60. Lamp Test.	5-18
5-61. Keyboard Test.	5-18
5-62. DAC Test.	5-18
5-63. Detector Linearity Test.	5-18

SECTION VI - PARTS LIST

6-1. INTRODUCTION.	6-1
----------------------------	-----

SECTION VII - SCHEMATIC DIAGRAMS

Figure 7-1. Frame Schematic, A1.	7-3
Figure 7-2. Display Board, A2A1, Assembly Diagram.	7-4
Figure 7-3. Display Board Schematic, A2A1.	7-5
Figure 7-4. Keyboard, A2A2, Assembly Diagram.	7-6
Figure 7-5. Keyboard Schematic, A2A2.	7-7
Figure 7-6. Control Board, A3, Assembly Diagram.	7-8
Figure 7-7. Control Board Schematic, A3, Sheet 1.	7-9
Figure 7-8. Control Board Schematic, A3, Sheet 2.	7-11
Figure 7-9. Control Board Schematic, A3, Sheet 3.	7-13
Figure 7-10. Mother Board, A4, Assembly Diagram.	7-14
Figure 7-11. Mother Board Schematic, A4.	7-15
Figure 7-12. H. V. Supply Board, A4A1, Assembly Diagram.	7-16
Figure 7-13. H. V. Supply Board Schematic, A4A1.	7-17
Figure 7-14. Oscillator Board, A5A1, Assembly Diagram.	7-18
Figure 7-15. Oscillator Board Schematic, A5A1.	7-19
Figure 7-16. Detector Board, A5A2, Assembly Diagram.	7-20
Figure 7-17. Detector Board Schematic, A5A2.	7-21
Figure 7-18. Amplifier Board, A5A3, Assembly Diagram.	7-22
Figure 7-19. Amplifier Board Schematic, A5A3.	7-23

List of Tables

Table	Page
Table 1-1. Performance Specifications.	1-2
Table 1-1. Performance Specifications Continued.	1-3
Table 2-1. Initial Conditions.	2-2
Table 3-1. Capacitance And Loss Formulas.	3-10
Table 3-2. Special Function Codes.	3-14
Table 3-3. End-of-string Character Selections.	3-15
Table 3-4. SETUP Mode Selections.	3-18
Table 3-5. Option/Test Switch Selections.	3-19
Table 3-6. Error Codes.	3-20
Table 3-7. IEEE-488 Bus Mnemonics.	3-21
Table 3-8. Serial Poll Status Byte Decoding.	3-22

Table 3-9. IEEE-488 Bus Command Responses.	3-23
Table 5-1. Recommended Test Equipment and Tools.	5-2
Table 5-2 Phase Error Effect On Conductance (G).	5-4
Table 5-3 Phase Error Effect On Capacitance (Cp).	5-5
Table 5-4. Test Level Functional Test.	5-10
Table 5-5. Capacitance (Cp) Accuracy Test.	5-10
Table 5-6 Conductance (G) Accuracy Test.	5-10
Table 5-7 Capacitance Analog Output Linearity Test.	5-11
Table 5-8 Conductance Analog Output Linearity Test.	5-11
Table 5-9 Internal Bias Accuracy Test.	5-11
Table 5-10 External Bias Accuracy Test.	5-12
Table 5-11 Input Loading Test.	5-12
Table 5-12. List and Location of Adjustments.	5-15
Table 5-13. Key Codes.	5-18
Table 6-1. Manufacturers's Federal Supply Codes.	6-1
Table 6-2. Replaceable Parts List.	6-2
Table 7-1. List of Schematics.	7-1

List of Figures

Figure	Page
Figure 1-1. Outline Dimensions.	1-4
Figure 2-1. Packing and Unpacking Diagram.	2-4
Figure 3-1. Instrument Displays and Indicators.	3-2
Figure 3-2. Measurement Function Keys.	3-3
Figure 3-3. Bias Function Keys.	3-5
Figure 3-4. Miscellaneous Function Keys.	3-6
Figure 3-5. Data Entry Keypad.	3-7
Figure 3-6. Front Panel Connectors And Power Control.	3-8
Figure 3-7. Rear Panel Connectors And Controls.	3-9
Figure 3-8. External Pulse Bias Circuitry.	3-11
Figure 3-9. Capacitance Correction Curves.	3-12
Figure 3-10. Typical Plot of a Varactor Diode.	3-16
Figure 4-1. Functional Block Diagram.	4-1
Figure 4-2. Measurement Circuits Block Diagram.	4-3
Figure 5-1. Loading Capacitor.	5-3
Figure 5-2. Input Loading Test Setup.	5-8
Figure 5-3. Adjustment Location Diagram.	5-14

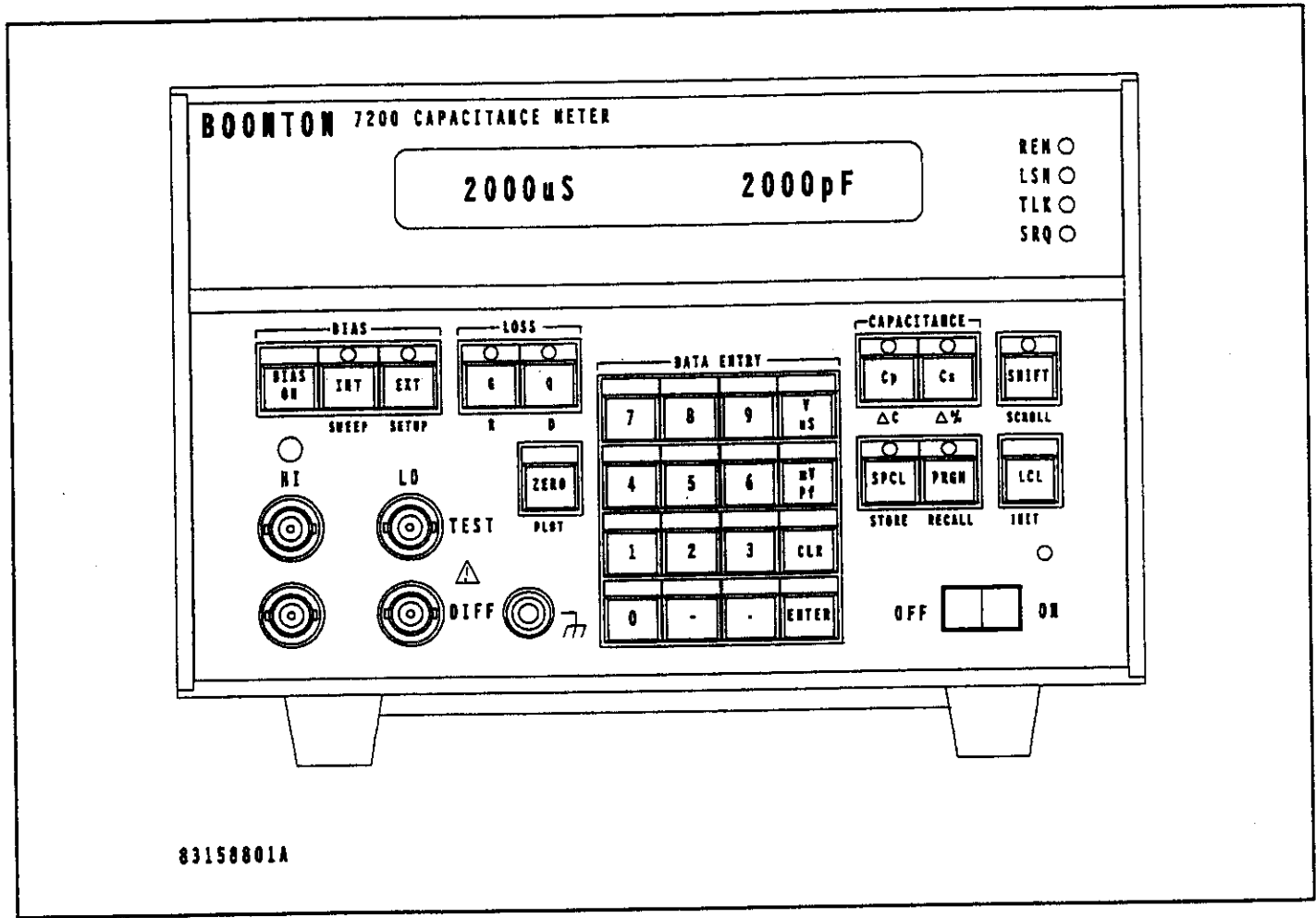

Model 7200 Capacitance Meter

SECTION I

GENERAL INFORMATION

1-1. INTRODUCTION.

1-2. This instruction manual provides general information, installation and operating instructions, theory of operation, and maintenance information for the Model 7200 Capacitance Meter.

1-3. DESCRIPTION.

1-4. The Model 7200 is a microprocessor-based capacitance meter which provides fully automatic, 1 MHz capacitance and loss measurements. Its operating capacitance range is 0 to 2000 pF, and its conductance range is 0 to 2000 μ S. The following features make the Model 7200 suitable for a wide variety of applications.

a. **Versatile Displays.** The Model 7200 measures the parallel capacitance and conductance of the device under test. From these measured parameters, it can calculate and display the equivalent series and parallel resistance, series capacitance, dissipation factor, and quality factor. Capacitance can also be displayed as a deviation from a programmable reference value in % or pF units.

b. **Accuracy.** The basic accuracy of Model 7200 for capacitance measurements is 0.25 % of reading + 0.2 % of full scale + 0.005 pF, and the basic accuracy for conductance measurements is 2.5 % of reading + 2.0 % of full scale + 0.05 μ S + $2(\omega C)^2$, where C is the parallel capacitance in Farads.

c. **Programmable Bias and Test Level.** The Model 7200 utilizes a 1 MHz test signal with programmable levels of 15, 30, 50, or 100 millivolts. It accepts, measures, and displays external DC bias voltages over a range of \pm 200 volts. An internal bias power supply is programmable over a \pm 100 volt range. Bias voltages of either polarity can be applied to the HI test terminals. This bias capability with fast responding C, G, and V outputs makes the instrument ideal for C-V or G-V semiconductor plots, as well as DLTS material studies.

d. **Wide Zeroing Range.** The Model 7200 can zero stray capacitances of up to 2000 pF automatically with a single keystroke. As a result of this wide zeroing capability, the range of the instrument can be effectively increased to 4000 pF by first zeroing the instrument with a 2000 pF specimen connected to the input terminals.

e. **Ease of Operation.** Human engineering con-

siderations have been emphasized in both the mechanical and electrical design of Model 7200. Measurement modes, test signal levels, bias voltages, and reference capacitance and conductance values are easily programmable with front-panel keystrokes. Ranging and measurement are fully automatic. Measured values and settings are displayed on a 20-character vacuum-fluorescent display with units of measurement to minimize the possibility of misinterpretation. LEDs indicate active keys.

f. **Panel Setup Storage and Recall.** The Model 7200 can store up to 99 complete panel setups in nonvolatile memory. Each stored setup can be recalled by entering the stored program number either locally or through the GPIB bus. This feature is especially useful when a series of often-repeated test sequences needs to be performed.

g. **IEEE-488 Interface.** The Model 7200 uses a microprocessor with a fixed internal program for automatic control of all measurement, computation, and display functions. The use of a microprocessor facilitates interfacing with ATE systems. The Model 7200 is equipped with a full-function IEEE-488 bus interface. All front panel control functions, with the exception of the PLOT and LCL/INIT key functions, are remotely programmable. For rapid data transfer, C, G, and V information is available simultaneously.

h. **Analog Outputs.** Analog voltages proportional to measured values of capacitance, conductance, and bias are continuously available at rear panel connectors for application to an analog plotter.

i. **Remote Measurements.** Because of its tolerance of loading capacitances, the Model 7200 is particularly useful for measurements at a point remote from the front panel test terminals, such as in environmental chambers, in areas of harmful radiation, or in component handlers for production testing.

j. **Special Functions.** A variety of special functions are provided to extend the operational capabilities of Model 7200 to meet specific requirements. The instrument can be configured to hold a particular measurement range when parameters of test specimens fall within a known range. Measurement limits can be programmed, and the instrument will indicate if the measurements for the test specimen are above or below these limits. The averaging filter length can be selected from no averaging up to 500 measurements. Internal temperature and temperature influence on measure-

Table 1-1. Performance Specifications.

MEASUREMENT SPECIFICATIONS	
Capacitance Measurement	
Range: (full scale) 2, 20, 200, and 2000 pF	Accuracy: 2.5 % of reading + 2 % of full scale + $0.05 \mu\text{S} + 2(\omega\text{C})^2$ where C is the parallel capacitance in Farads
Resolution: 0.001 pF, 0 to 2 pF 0.01 pF, 2 to 20 pF 0.1 pF, 20 to 200 pF 1 pF, 200 to 2000 pF	External Bias Measurement
Accuracy: 0.25 % of reading + 0.2 % of full scale + 0.005 pF	Range: ± 200 volts Resolution: 0.1 volt Accuracy: 0.25% of reading + 4 counts
Conductance Measurement	
Range: (full scale) 2, 20, 200, and 2000 μS	Temperature Influence
Resolution: 0.01 μS , 0 to 2 μS 0.1 μS , 2 to 20 μS 1 μS , 20 to 200 μS 10 μS , 200 to 2000 μS	Operating Temperature: 10 to 40 °C Amplitude Error: $\pm 0.017 \%/^{\circ}\text{C}$ Phase Error: $\pm 0.2^{\circ}\text{C}$ Warm-up Time: 2 hours

ments can be displayed. Special functions can also be used with external standards to calibrate the instrument from the front panel or over the IEEE-488 interface.

1-5. ACCESSORIES.

1-6. The available accessories are listed in Table 1-1.

1-7. OPTIONS.

1-8. No available options at this time.

1-9. SPECIFICATIONS.

1-10. Performance specifications for the Model 7200 Capacitance Meter are listed in Table 1-1.

Table 1-1. Performance Specifications Continued.

SUPPLEMENTAL INFORMATION	General Information
Computed Parameters	IEEE-488 Bus Interface
Series Capacitance: 0.000 to ± 9999 pF	Complies with IEEE-488-1978, implements AH1, SH1, T6, TE0, L4, LE0, SR1, RL1, PP0, DC1, DT1, C0 and E1
Series Resistance: 0.00 Ω to ± 9.999 M Ω	Power Requirements:
Parallel Resistance: \pm (488.5 W to 9.999 M Ω)	100, 120, 220, or 240 VAC, ± 10 %, 50 to 400 Hz, 35 VA
Dissipation Factor: 0.000 \pm 999.9	Ventilation Requirements:
Quality Factor: 0.000 to ± 999.9	1 1/2" clearance after installation, top, side, rear
Delta Capacitance: 0.000 to ± 9999 pF	Temperature:
Delta Percent: 0.00 to ± 99.99 %	Operating: 0 - +55°C Non-operating: -40 - +75°C
Test Signal	Altitude:
Frequency: 1.0 MHz, crystal controlled	Operating: 10,000 ft
Level: 15, 30, 50, or 100 mV, programmable	Non-operating: 15,000 ft
Internal Bias Source	Humidity: 95% (non-condensing)
Range: ± 100 V	Battery Type: Refer to parts list page 6-4
Maximum Current: 5 mA	Weight: 12 lb (5.4 kg)
1 mV for voltages less than or equal to 20 V	Dimensions: See Figure 1-1
10 mV for voltages above 20 V	CE Mark: Declares Conformity to European Community (EC) Council Directives: 89/336/EEC//93/68/EEC, 73/23/EEC//93/68/EEC & Standards: EN55011, EN50082-1, EN61010-1
Accuracy: 0.5 % of setting + 10 counts	Accessories Supplied: AC power cord
Rear Panel Connectors	Accessories Available:
External Bias Input:	76-2A series Capacitance standards, for use in calibration & performance verification
± 200 V maximum, 1/16A fuse protected	76-4A series Conductance standards, for use in calibration & performance verification
Capacitance Analog Output: (Parallel Capacitance)	950000000 Rack-mounting kit, single
2 V full scale	950001000 Rack-mounting kit, dual
Source Resistance: 1000 Ω	950041000 Rack-mounting kit, single, with slides
Linearity: 0.1 % of reading + 0.05% of full scale	950037000 Rack-mounting kit, dual, with slides
Loss analog Output: (Conductance)	950038000 Rack-mounting kit, single, with slides and drawer
2 V full scale	950038000 Transit case
Source Resistance: 1000 Ω	95300002A Chip capacitor fixture
Linearity: 0.1% of reading + 0.05% of full scale	95313301A Remote test fixture
Bias Analog Output: 10 mV/V	950002000 Rack mounting kit, to mount with older, half-rack installation
Source resistance: 1000 Ω	

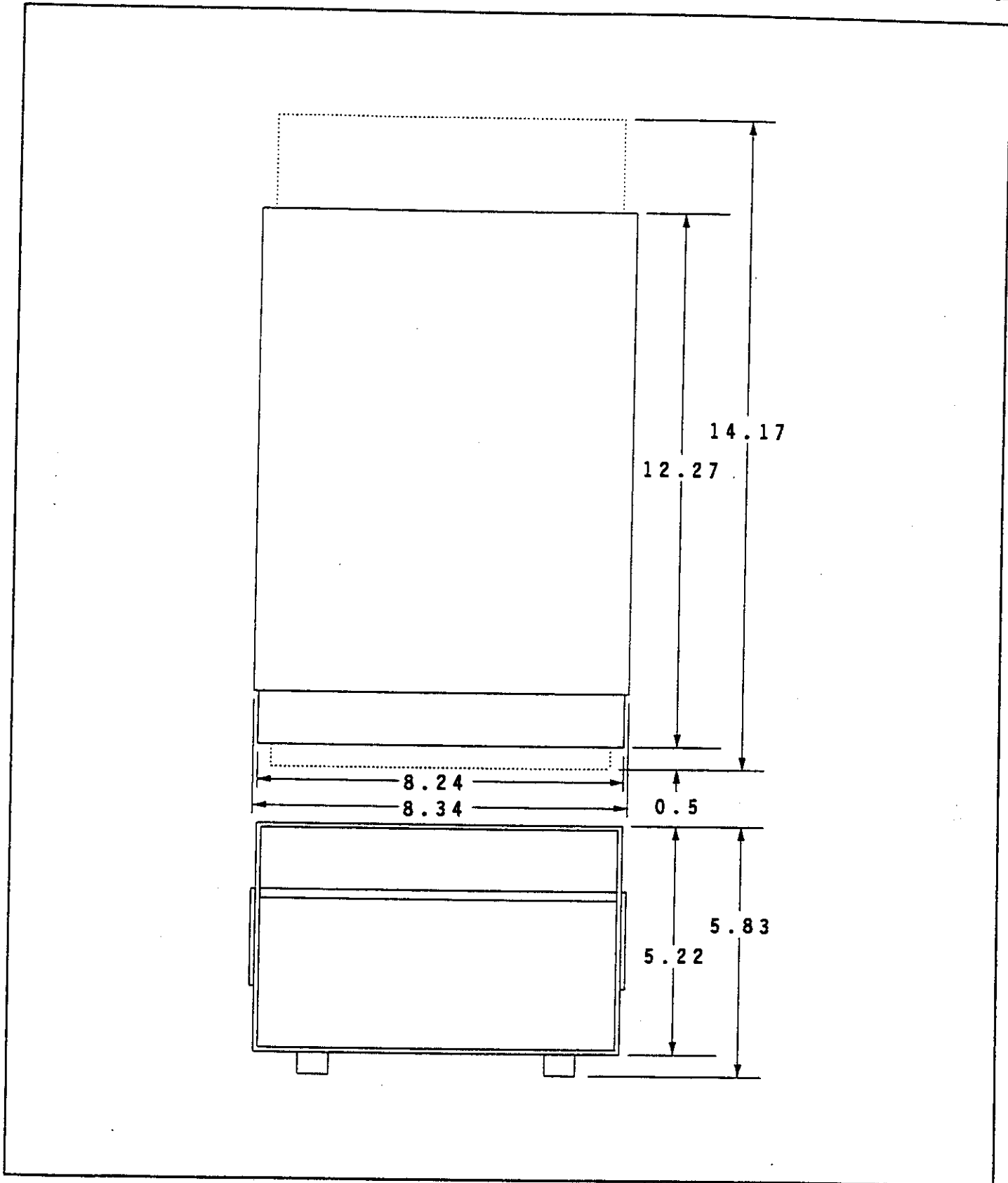

Figure 1-1. Outline Dimensions.

SECTION II INSTALLATION

2-1. INTRODUCTION.

2-2. This section contains the unpacking, mounting, power requirements, cable connections, and preliminary check instructions for the Model 7200 Capacitance Meter.

2-3. UNPACKING.

2-4. The instrument is shipped complete and is ready to use upon receipt. Unpack the instrument from its shipping container and inspect for damage that may have occurred during shipment. Refer to Figure 2-1.

NOTE

Save the packing material and container for possible use in reshipment of the instrument.

2-5. MOUNTING.

2-6. For bench mounting choose a clean, sturdy, uncluttered mounting surface. For rack mounting, accessory kits are available. Refer to Table 1-1 for available accessories. The rack mounting kits contain the required hardware and instructions.

2-7. POWER REQUIREMENTS.

2-8. The instrument has a tapped power transformer and two line voltage selection switches which permit operation from 100, 120, 220, or 240 volt, $\pm 10\%$, 50 to 400 Hz, single phase AC power sources.

CAUTION

Always make certain that the line voltage selection switches are set to the correct positions corresponding to the voltage of the AC power source, and that a fuse of the correct rating is installed before connecting the instrument to any AC power source.

Line Voltage Select Chart

VAC $\pm 10\%$	100 120	220 240	50 to 400 Hz
Fuse	3/8 AT	0.2 AT	35 VA

2-9. Set the rear panel line voltage selector switches to the appropriate positions as indicated in the Line Voltage Select Chart and check that the line fuse is correct for the selected power source.

2-10. FRONT PANEL CONNECTIONS.

2-11. **Test Terminals.** The device that is to be tested is connected to the instrument through the front-panel, type BNC, TEST connectors. Connections may be made directly, through the accessory chip capacitor fixture, or the accessory remote test fixture. If DC bias is to be applied to the specimen, the bias is applied through the TEST HI connector from the rear panel external bias input or the optional internal bias source. The 1 MHz test signal is applied through the TEST LO connector.

2-12. **Differential Terminals.** For differential measurements, the reference device is connected to the front-panel, type BNC, DIFF connectors directly or through the accessory chip capacitor fixture or remote test fixture. Bias voltage, if required, is applied to the specimen through the DIFF HI connector from the rear panel external bias input or the internal bias source. The 1 MHz test signal is applied through the DIFF LO connector.

2-13. REAR PANEL CONNECTIONS.

2-14. **External Bias.** The type BNC EXT BIAS INPUT connector on the rear panel provides a means for application of DC voltages from an external source to the TEST HI and DIFF HI connectors for biasing the measurement specimens. External bias voltages can be applied up to a maximum of ± 200 volts and 1/16 ampere (fuse protected). Bias voltage of either polarity may be applied to the EXT BIAS INPUT connector.

CAUTION

If external bias is applied directly to the specimen or to the front panel TEST HI or DIFF HI connectors, the BIAS ON and EXT modes must be enabled prior to application of the bias voltage. Never apply bias voltages to the TEST LO or DIFF LO terminals since they have very low DC resistance to chassis ground.

2-15. **IEEE-488 Bus Interface.** The rear-panel IEEE-488 BUS connector provides the means for connecting the instrument to an IEEE-488 bus for remote control. This connector

will accommodate a standard IEEE-488 bus connector.

2-16. Analog Outputs. DC voltages proportional to measured values of parallel capacitance, conductance, and bias are available at the type BNC, ANALOG OUT connectors on the rear panel. These analog DC voltages are available continuously during measurements. Voltage levels are 2 volts full scale, and source resistance is 1000 ohms.

NOTE

The ANALOG OUT CAP and LOSS voltages are proportional to measured parallel capacitance and conductance, respectively, even if computed values are selected for display on the instrument.

2-17. PRELIMINARY CHECK.

2-18. The preliminary check verifies that the Model 7200 is operational and should be performed before the instrument is placed into use. The required test equipment is listed in Table 5-1. To perform the preliminary check, proceed as follows:

- a. Connect the AC power cord to the instrument power receptacle and to a suitable AC power source.
- b. Set the front panel LINE switch to the ON position

and verify that the following events occur in the order given:

- 1) The LINE indicator should light.
- 2) "Boonton Electronics" should appear momentarily on the instrument display.
- 3) "Program Code" followed by the firmware revision number should then be displayed.
- 4) All functions and operating modes of the Model 7200 are restored to the values and conditions before the power was interrupted.

c. Press the LCL/INIT key to initialize the instrument. The initialize sequence resets all functions and operating modes of the Model 7200 to the preset values and conditions listed in Table 2-1.

2-19. Check operation of the 1 MHz test signal circuits as follows:

- a. Connect an RF millivoltmeter to the front panel TEST LO connector.
- b. Press the SPCL key and verify that "spcl 0" appears on the instrument display.

Table 2-1. Initial Conditions.

Function/Mode	Condition
Loss Display Mode	Conductance (G)
Capacitance Display Mode	Parallel Capacitance (Cp)
Test Level Function	100 mV
Capacitance Standard Function	0.000 pF
Conductance Standard Function	0.00 μ S
Capacitance Low Limit Function	-9999 pF
Capacitance High Limit Function	9999 pF
Special Function	0
Program Location Function	99
Internal Bias Function	0.000 V
Bias Start Function	0.000 V
Bias Stop Function	0.000 V
Bias Step Function	0.000 V
Plot Mode	Parallel capacitance (Cp) vs Bias
X Axis Scale Mode	Auto
Y Axis Scale Mode	Auto
Sweep Mode	Off
Bias Mode	Off
IEEE-488 Address Function	Unchanged
End-of-string Character	Unchanged
IEEE-488 Talk Mode	Talk value (TV)

c. Select special function 1 by pressing the (1) key on the DATA ENTRY keypad. The instrument display should change to display an apostrophe and the number 1.

d. Press the ENTER key on the DATA ENTRY keypad. The instrument display should show "Test Level" followed by the active test level value: "100mV".

e. Select a test level of 15 millivolts by pressing the (1), (5), and mV keys on the DATA ENTRY keypad. The instrument display should show "Test Level 15mV".

f. Verify that the RF millivoltmeter reads approximately 15 millivolts.

g. Repeat step (e), except select test levels of 30, 50, and 100 millivolts in succession. When each of these test levels has been entered, verify that the RF millivoltmeter reading approximately corresponds to the selected value.

h. Disconnect the RF millivoltmeter.

2-20. Check operation of the external bias circuits as follows:

a. Connect the DC voltmeter to the front panel TEST HI connector.

b. Connect a DC power supply to the rear panel EXT BIAS INPUT connector. Either polarity may be used. Adjust the output voltage of the DC power supply to approximately 15 volts.

c. Press the EXT key on the front panel. The LED in the key should light and the left section of the instrument display should contain the measurement of the applied bias voltage.

d. Press the BIAS ON key on the front panel. The BIAS ON indicator should light green. Verify that the bias voltage value shown on the instrument display agrees with that shown on the DC voltmeter.

e. Press the BIAS ON key again. The BIAS ON indicator should go off and the DC voltmeter reading should drop to zero.

f. Adjust the output voltage of the DC power supply to a value between 20 and 200 volts.

g. Press the BIAS ON key and verify that the BIAS ON indicator lights red and the displayed bias voltage value agrees with that shown on the DC voltmeter.

h. Press the BIAS ON key. Turn off the DC power supply and disconnect the power supply and DC voltmeter from the instrument connectors.

2-21. Check operation of the capacitance and conductance measurement circuits as follows:

a. Press the ZERO key on the front panel. The instrument display should show "Meter Zero" followed by a bar for each of the four ranges as they are zeroed. When zeroing has been completed, both sections of the instrument display should show zero numerical values for G and Cp measurements.

b. Connect a capacitance of known value between the TEST HI and TEST LO connectors.

c. Press the G and Cp keys. Verify that the LEDs in these keys light and that the conductance and parallel capacitance values are displayed.

d. Press the Cs key. Verify that the LED in this key lights and that the equivalent series resistance and series capacitance are displayed.

e. Press the Q key. Verify that the LEDs in this key lights and that the quality factor is displayed.

f. Set the LINE switch to OFF and disconnect the capacitor.

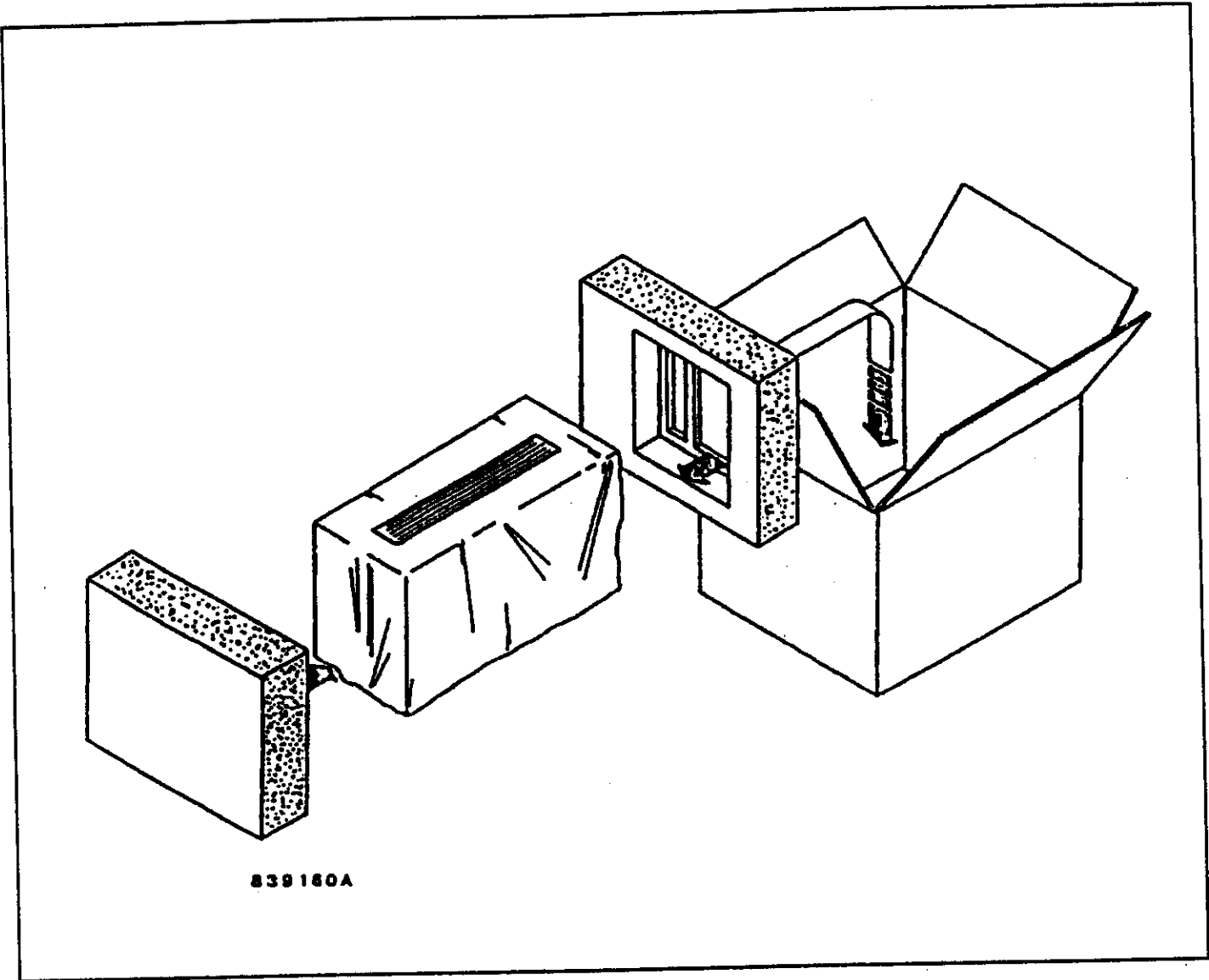

Figure 2-1. Packing and Unpacking Diagram.

SECTION III OPERATION

3-1. INTRODUCTION.

3-2. This section contains operating instructions for the Model 7200. It is highly recommended that the operator become familiar with all the material in this section before attempting to operate the instrument; otherwise, the full capabilities of the instrument may not be realized.

3-3. CONTROLS, INDICATORS, AND CONNECTORS.

3-4. The Model 7200 operating controls, indicators, and connectors are divided into functional groups. The functional groups consist of the following:

- a. **Instrument Displays and Indicators** are used to display messages, measurements and programming values and to indicate IEEE-488 bus activity.
- b. **Measurement Function Keys** are used to select the measurement modes and to zero the instrument.
- c. **Bias Function Keys** are used to select and apply bias voltage to the test specimens and to plot response curves.
- d. **Miscellaneous Function Keys** are used to select special functions, store and recall panel setups, initialize the instrument and return the instrument to local, front-panel control.
- e. **Data Entry Keypad** is used to enter numerical values for selected functions.
- f. **Front Panel Connectors and Switches** are used to control application of line power to the instrument and to connect the test specimen to the instrument.
- g. **Rear Panel Connectors and Switches** are used to connect the instrument to the ac power and DC bias sources and peripheral devices, to protect the power and DC bias circuits against overload, and to configure the input ac power circuits of the instrument for various input line voltages.

3-5. The controls, indicators, and connectors of the functional groups are shown in Figures 3-1 through 3-7. Paragraphs 3-6 through 3-31 provide a more detailed description of these items. Note that some of the front-panel keys have two designations, one on the key and the other below the key. These keys are dual function keys. The function of keys with blue

alternate designations depends on the SHIFT key status. In the unshifted mode (LED in SHIFT key is not lighted), the function indicated by the designation on the key is applicable. In the shifted mode, the function indicated in blue below the key is applicable. Shifting between the two modes is done using the SHIFT key. Alternate designations in black are applicable, without shifting, for specific instrument operating conditions. LEDs in selected function keys light when the functions are active. Throughout this manual it will be understood that when a key is referred to by the blue nomenclature below it, the shift key must be activated prior to pushing that key.

3-6. **Instrument Displays and Indicators.** Refer to Figure 3-1. The instrument uses a 20-character, vacuum fluorescent display. The entire display is used for most data entry and message functions; for measurement values, the display is divided into two sections. The left 10 characters are used to display the value of the active bias or loss function. The right 10 characters are used to display the value of the active capacitance, special or program location function. An arrow symbol (→) will appear in the first character of either window as an indication of the active window for DATA ENTRY operation. In some special modes of operation the full 20-character display is used to indicate the description and value.

3-7. A dual-color indicator is located directly below the BIAS ON key. This indicator lights when bias is being applied to the test specimen from within the instrument. If the bias voltage exceeds 20 volts the indicator will light red; for values of 20 volts or less, it will light green. This indicator is extinguished when the bias is off.

3-8. The IEEE-488 bus annunciators display the current IEEE-488 bus interface status. When the Model 7200 is used in a system application the instrument displays and indicators with the exception of the IEEE-488 bus status annunciators can be extinguished using the blank display command (BL). The update display command (UD) restores the display to normal operation.

3-9. **Measurement Function Keys.** Refer to Figure 3-2. The measurement function keys consist of the LOSS function group, CAPACITANCE function group and ZERO keys. These keys may be used at any time to change current measurement parameters and display updates. The parallel capacitance (CP) and conductance (G) are direct measurement parameters. All other LOSS and CAPACITANCE

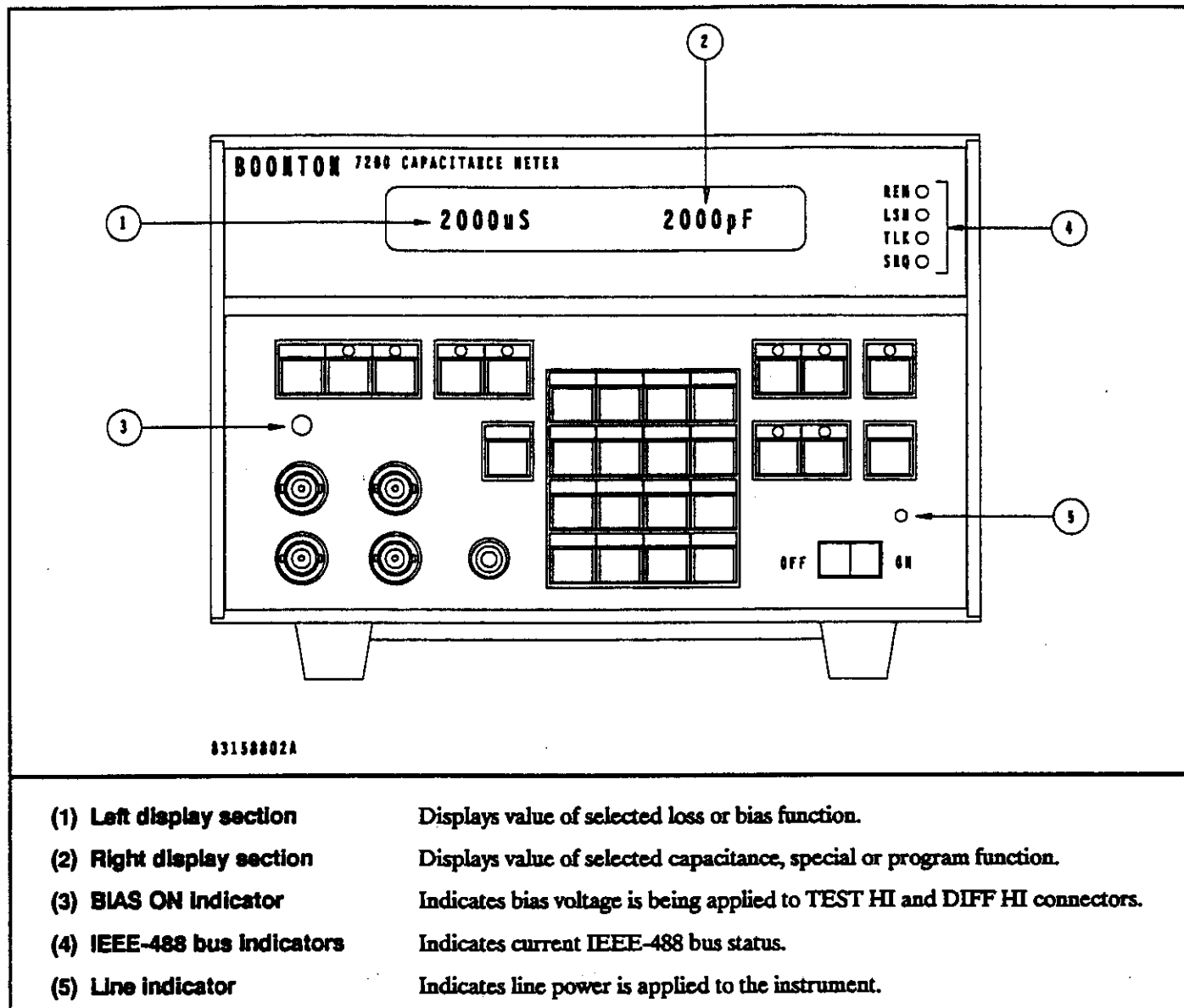

Figure 3-1. Instrument Displays and Indicators.

modes are values calculated from the measurements.

3-10. LOSS Function Keys. Loss measurement parameters are selected for display on the left section of the instrument display using the dual-function LOSS keys. The keys are interlocked so that only one loss function is active at a time. The loss of the test specimen can be displayed as parallel conductance (G), quality factor (Q), series resistance (Rs), parallel resistance (Rp) or dissipation factor (D). If the conductance (G) mode is selected while the CAPACITANCE display indicates series capacitance (Cs), the parallel capacitance (Cp) mode will automatically be displayed. The resistance (R) function can be displayed as parallel (Rp) or series (Rs) resistance. The parallel resis-

tance (Rp) of the test specimen is displayed while the Cp mode is active and the series resistance (Rs) of the test specimen is displayed while the Cs mode is active.

3-11. CAPACITANCE Function Keys. Capacitance measurement parameters are selected for display on the right section of the instrument display using the dual-function CAPACITANCE keys. Only one capacitance display function is active at a time. In the unshifted mode, either the parallel capacitance (Cp) or series capacitance (Cs) may be selected for display. If the Cs mode is selected while the LOSS display indicates conductance (G) or parallel resistance (Rp), the series resistance (Rs) mode will automatically be displayed. In the shifted mode, the difference between the

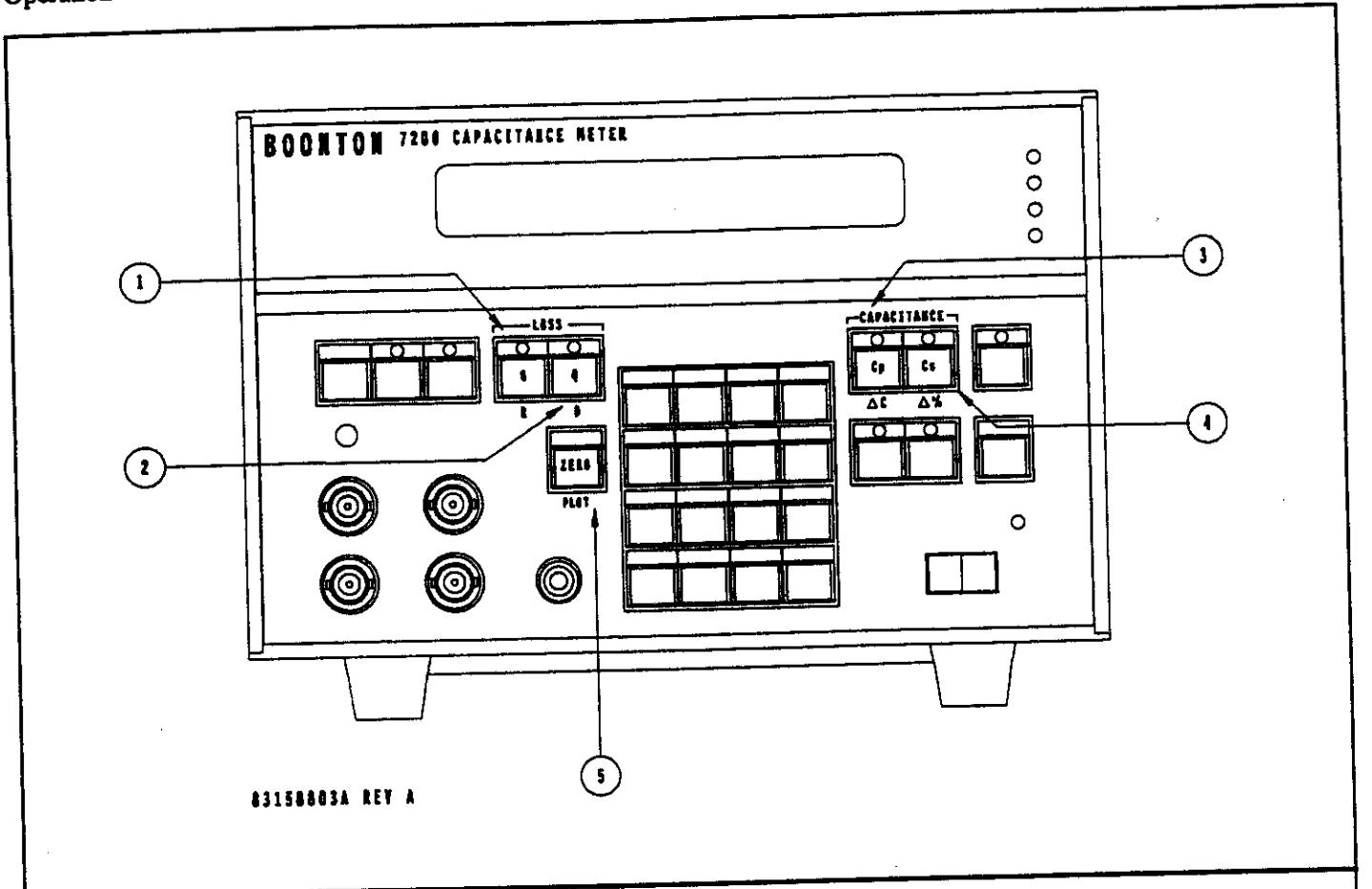

- (1) LOSS G/R key.** In unshifted mode, selects conductance (G) of test specimen to be displayed on left section of the display; forces capacitance display from series to parallel mode.
In shifted mode, selects series or parallel resistance of test specimen to be displayed on left section of the display.
- (2) LOSS Q/D key.** In unshifted mode, selects quality factor (Q) of test specimen to be displayed on left section of the display.
In shifted mode, selects dissipation factor (D) of test specimen to be displayed on left section of the display.
- (3) CAPACITANCE Cp/ΔC key.** In unshifted mode, selects parallel capacitance (Cp) of test specimen to be displayed on right section of instrument display; forces the loss resistance display into the parallel resistance mode (Rp).
In shifted mode, selects the difference between the measurement and standard capacitance to be displayed on right section of the display.
- (4) CAPACITANCE Cs/Δ% key.** In unshifted mode, selects series capacitance (Cs) of test specimen to be displayed on right section of display; forces the loss resistance and conductance display into the series resistance mode (Rs).
In shifted mode, selects the percentage difference between the measurement and standard capacitance to be displayed on right section of the display.
- (5) ZERO key.** In unshifted mode, initiates automatic zeroing operation.

Figure 3-2. Measurement Function Keys.

parallel or series capacitance of the test specimen and a reference capacitance standard can be selected for display. The capacitance standard is programmed into the instrument using special function 2. The value can be displayed as a deviation in capacitance (ΔC) or as a percentage ($\Delta\%$).

3-12. ZERO Key. One of the most important measurement keys is the ZERO key. It is used to remove test terminal residuals from the measurements, and is active at all times. Zeroing should be performed when the test level is changed, the test connection configuration is altered, or when displayed measurement data indicate significant parallel capacitance or conductance residue. When the ZERO key is pressed, normal display activity is halted, and a "Meter Zero" message is displayed. One bar appears after this message for each of the four ranges as the ranges are zeroed. When zeroing has been completed, the instrument display returns to its previous display mode. If the measurement range is held (special functions 11 through 15) only the selected range will be zeroed.

3-13. BIAS Function Keys. Refer to Figure 3-3. The bias function keys consist of the BIAS ON, INT, EXT, SWEEP, SETUP and PLOT keys. These keys enable the operator to select either external or internal bias voltage for display on the left section of the instrument display, to apply the selected bias voltage to the test specimen and to configure the internal bias sweep and plot modes.

3-14. BIAS ON, INT And EXT Keys. The BIAS ON key is an alternate action key which toggles on and off the external or internal bias to the test specimen. When the EXT key is pressed the measured value of the bias voltage is shown on the left section of the display. When the INT key is pressed the bias voltage setting is shown on the left section of the display. Internal bias voltage can be adjusted using the DATA ENTRY keypad.

3-15. SETUP Key. The SETUP key allows access to sweep and plot parameter functions which configure the instrument to make annotated plots of a series of measurements. The sweep parameter functions consist of bias start, stop and step values. The plot parameter functions consist of the plot mode, X axis scale and Y axis scale selections. Refer to Table 3-4 for a description of the sweep and plot parameter functions.

3-16. When the SETUP key is pressed the first sweep parameter function is displayed. Required data is entered using the DATA ENTRY keypad. Pressing the ENTER key without numerical arguments will cause the next parameter function to be displayed. After the sweep parameters are selected the first plot parameter function is displayed. The plot parameter functions are menu-type functions. The various selections are accessed using the SHIFT/SCROLL key. Pressing the ENTER key will cause the next parameter function to be displayed. The setup mode is terminated after

all the parameter functions have been accessed or when any function key is pressed.

3-17. SWEEP Key. The SWEEP key enables the instrument to make a series of test specimen measurements based on the sweep parameter functions of the setup mode. Analog voltages proportional to measured values are available at the rear-panel CAP, LOSS and BIAS outputs for connection to an X-Y recorder. When the SWEEP key is pressed the active function is changed to internal bias and the internal bias supply is set to the bias start value. The instrument will automatically increment the internal bias voltage by either the calculated minimum step size (500 data points) or the selected bias step value, whichever is greater. The sweep will terminate when the internal bias value reaches the bias stop value. Pressing the CLR key or attempting any numeric entry during a sweep will also terminate the sweep mode.

NOTE

BIAS ON must be enabled before the SWEEP mode is activated otherwise the bias voltage will not be applied to the test specimen.

3-18. PLOT Key. The PLOT key is used to generate and transmit HPGL formatted data to a compatible plotter connected to the IEEE-488 bus. The internal program of the instrument requires that the plotter bus address be set to address 30. The PLOT key is inactive while another controller asserts remote-enable (REN) on the IEEE-488 interface or when there is no sweep data available. The sweep data consists of bias, conductance and parallel capacitance measurements stored in memory during the sweep. The plot parameter functions of the setup mode define the plot layout. When the PLOT key is pressed the display will contain the "Generating Plot Data" message while sweep data is converted to HPGL format. The data will be transmitted automatically to the plotter after the conversion is complete.

NOTE

The plot parameter functions of the SETUP mode can be changed and multiple plots generated from the same set of sweep data. A new SWEEP is required only when the sweep parameter functions are altered.

3-19. Miscellaneous Function Keys. Refer to Figure 3-4. The miscellaneous function keys consist of the SPCL, PRGM, STORE, RECALL, LCL/INIT and SHIFT/SCROLL keys. These keys enhance the basic operation of the instrument.

3-20. SPCL Key. A variety of special functions is provided to extend the operation of the instrument to meet specific requirements. Selection of a special function is made using the SPCL key and the DATA ENTRY keypad. If the selected

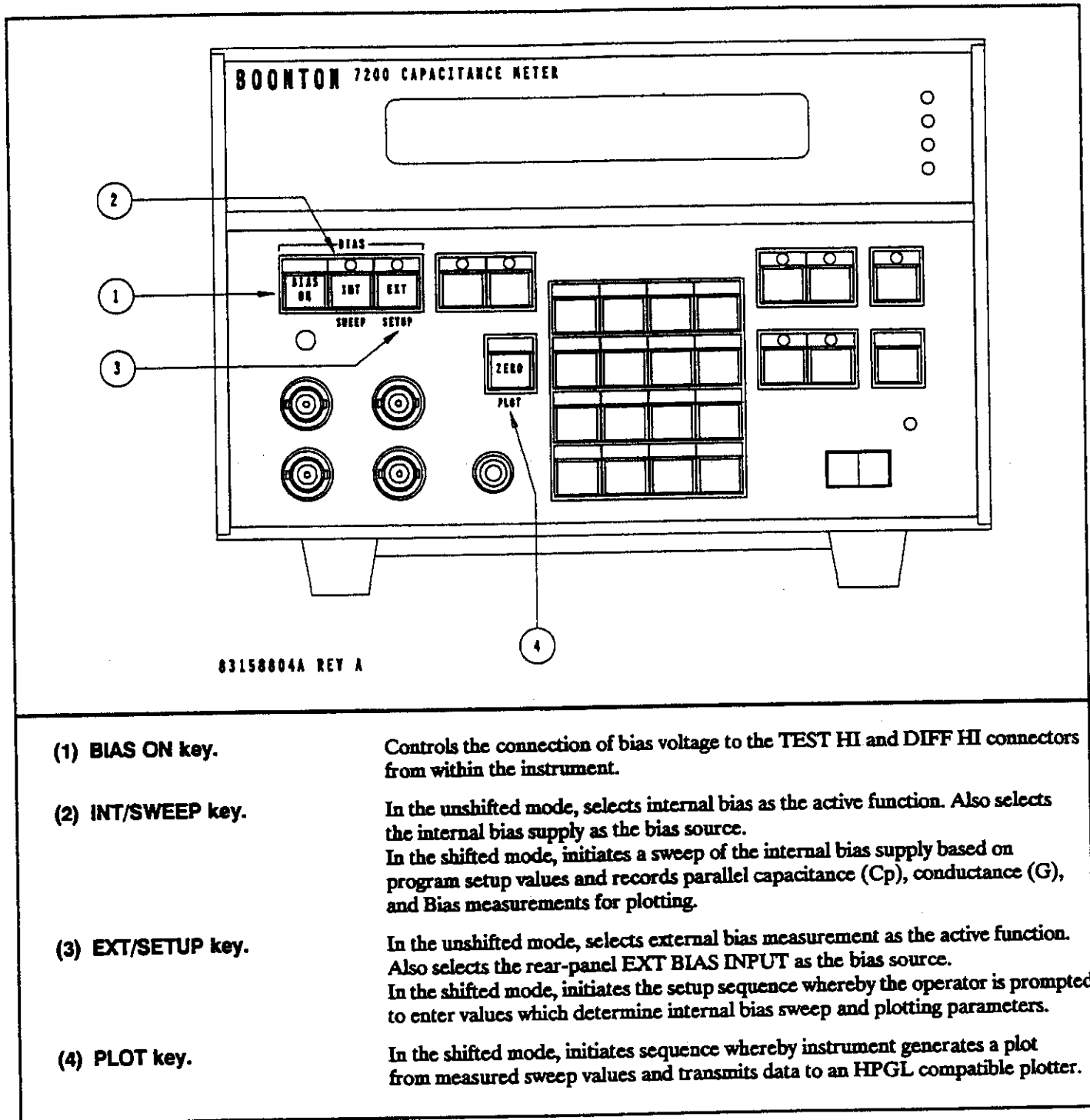

Figure 3-3. Bias Function Keys.

special function involves a choice of variables, the display can be scrolled to show the choices using the SHIFT/SCROLL key, and select using the ENTER key.

3-21. PRGM, STORE And RECALL Keys. To eliminate the need for repeated, time-consuming control setups, up to

99 front-panel setups may be stored in the instrument for subsequent recall. Setups are identified by program numbers specified using the PRGM key and the DATA ENTRY keypad. The current front-panel setup can be stored at the selected program location using the STORE key; the front-panel test setup stored at a selected location can be recalled

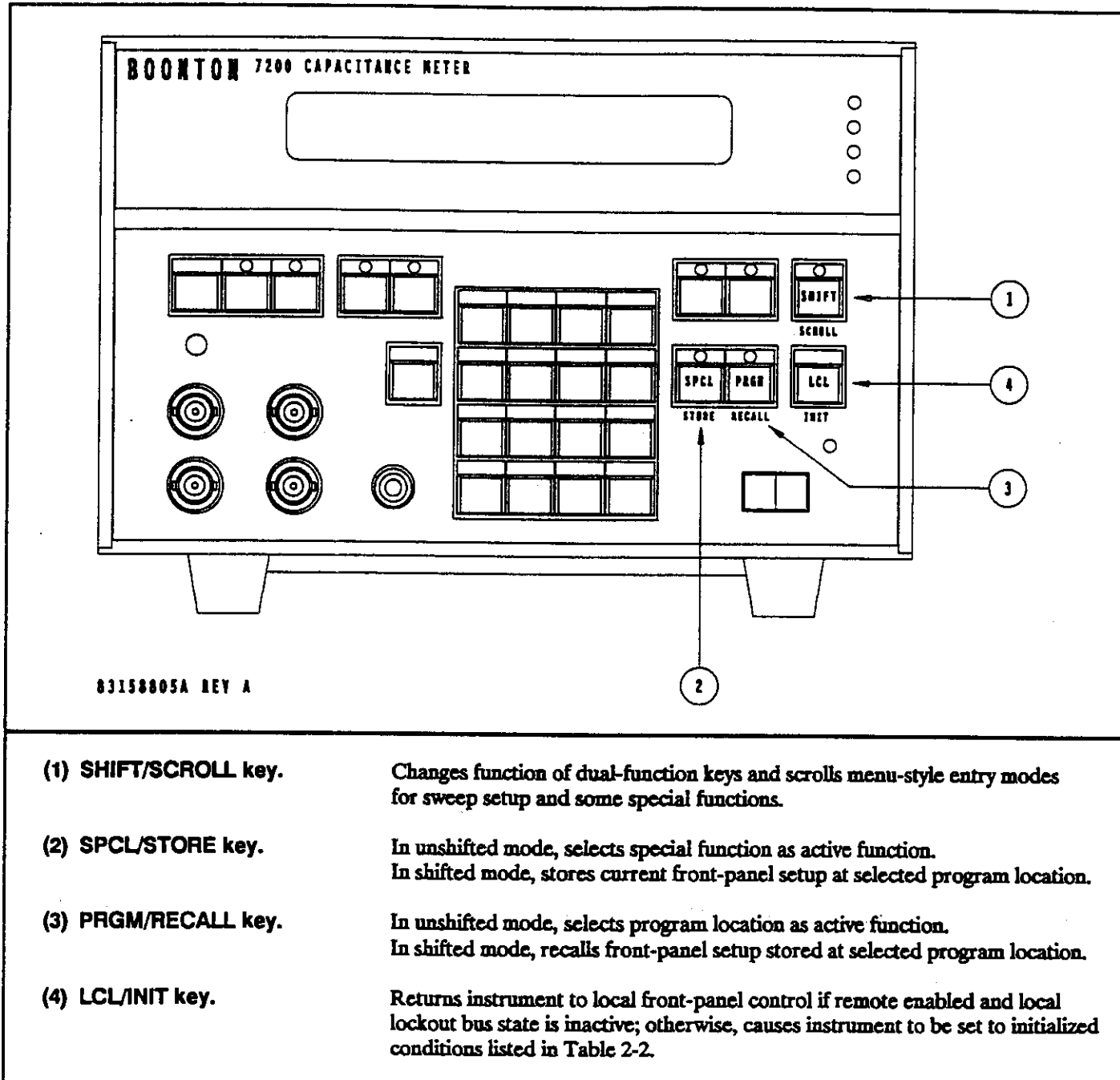

Figure 3-4. Miscellaneous Function Keys.

using the RECALL key. Program location 99 is a recall-only location which contains the initialize conditions described in Table 2-1.

3-22. LCL/INIT Key. This key is a dual-function key. If the key is pressed while the instrument is remote enabled and the local lockout bus state is not active, the instrument is returned to front-panel control. If the REM, LSN and TLK bus status annunciators are off, pressing the key results in an initializa-

tion restart. All function values and measurement modes are set to the initialized conditions described in Table 2-1.

3-23. SHIFT/SCROLL Key. The alternate action SHIFT/SCROLL key shifts the functions of the instrument dual-function keys. When the LED in the SHIFT key is lighted the next key pressed will activate the shifted function designated in blue characters below the key. The SHIFT key is also used to scroll the instrument display for parameter

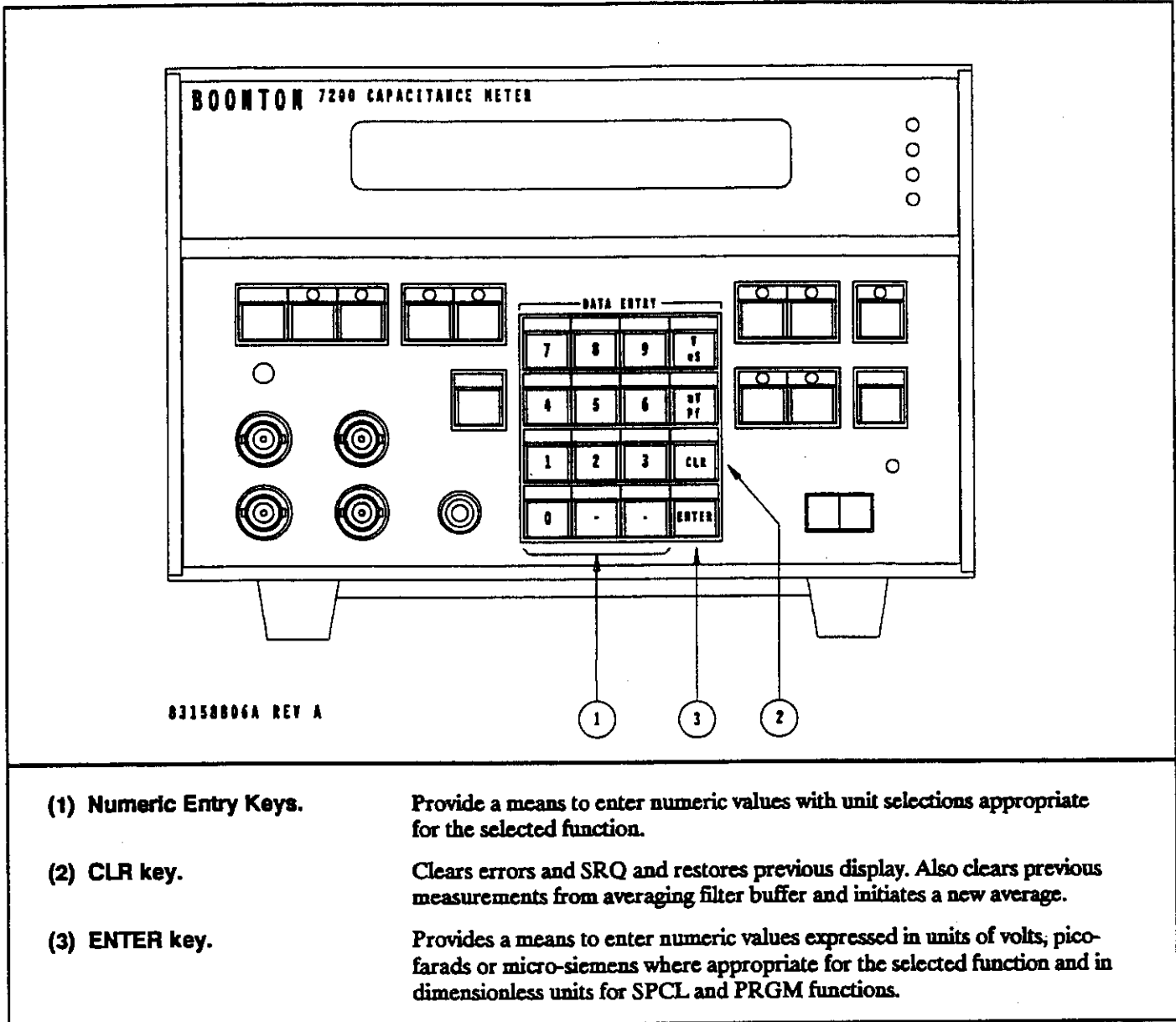

Figure 3-5. Data Entry Keypad.

selection during some special functions and sweep setup functions.

3-24. DATA ENTRY Keypad. The DATA ENTRY keypad enables the operator to enter numerical values for functions which allow parameter selection. Refer to Figure 3-5. The keypad is inactive for measurement functions. Operation of the DATA ENTRY keypad is conventional. As successive digits are keyed in, each will appear in the rightmost position on the display, with any previous digits shifted to the left. An apostrophe (') precedes the digits to indicate that the displayed value has not yet been entered. The entry is completed by pressing the ENTER key or the appropriate

unit key. Note that it is not necessary to enter any trailing zeroes. Voltage values may be entered in terms of millivolts or volts. The V and mV keys may also be used to rescale internal bias voltage display.

3-25. The CLR Key. The CLR key serves many functions. It is primarily used to recover from invalid entry and to restore normal operation after an error message is displayed. Pressing the CLR key will clear the error and then restore the previous display. The data entry process can then be resumed. Pressing the CLR key while sweeping internal bias disables the sweep. The CLR key will also clear SRQ and erase previous data from the measurement averaging filter

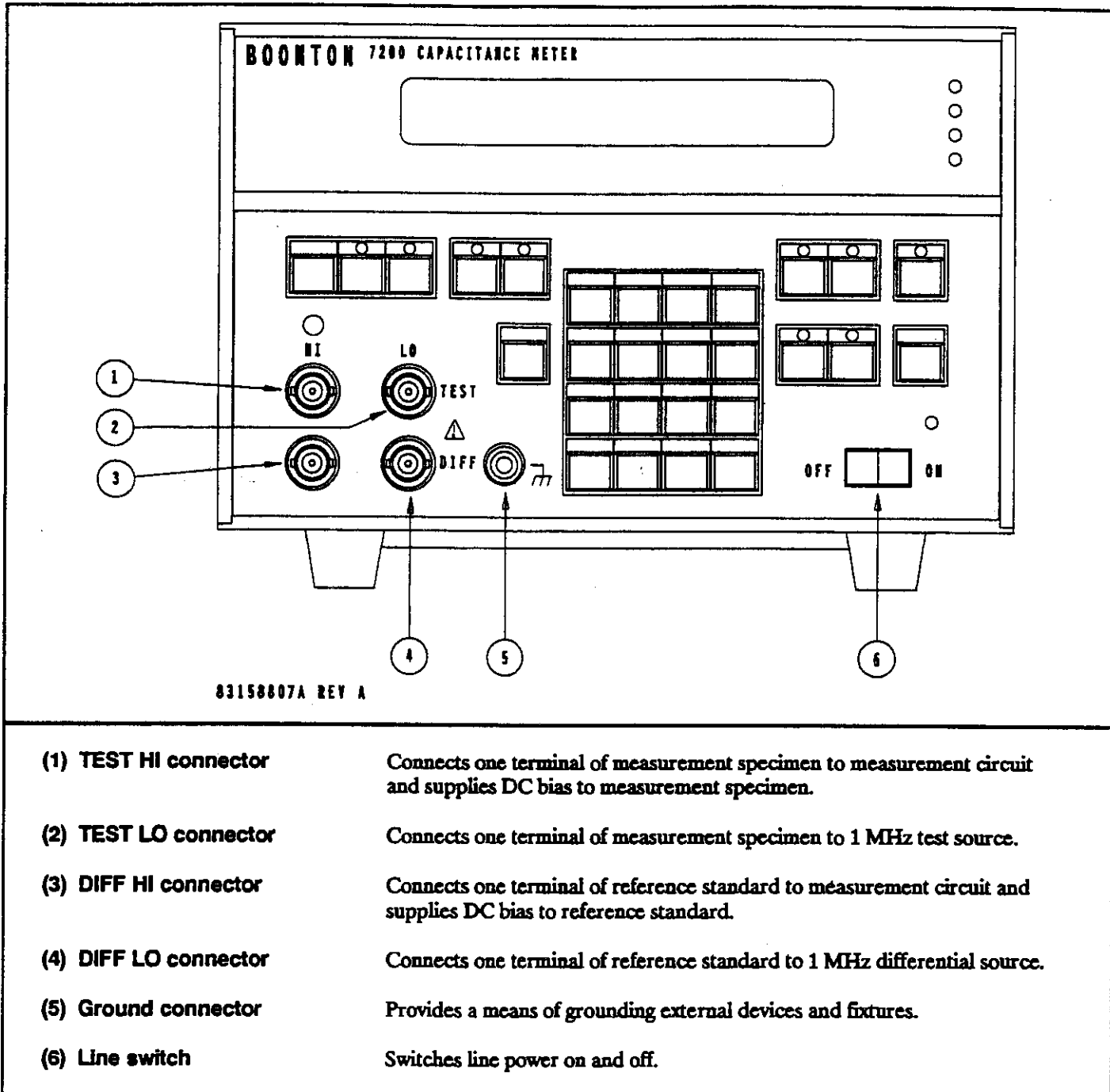

Figure 3-6. Front Panel Connectors And Power Control.

and begin a new average with subsequent measurements.

3-26. Front Panel Connectors. Refer to Figure 3-6. The Model 7200 has four type BNC front-panel connectors. The TEST HI and TEST LO connectors are used to connect the test specimen or test fixture to the measurement circuits. The DIFF HI and DIFF LO connectors are used to connect a reference capacitance directly or through a test fixture to the

measurement circuits for differential measurements. Bias voltage, if used, is applied to the TEST HI and DIFF HI connectors. The 1 MHz test signal is applied to the TEST LO and DIFF LO connectors.

3-27. Rear Panel Connectors. Refer to Figure 3-7. Three analog output connectors, an external bias input connector, a power receptacle, line voltage selector switches, and two

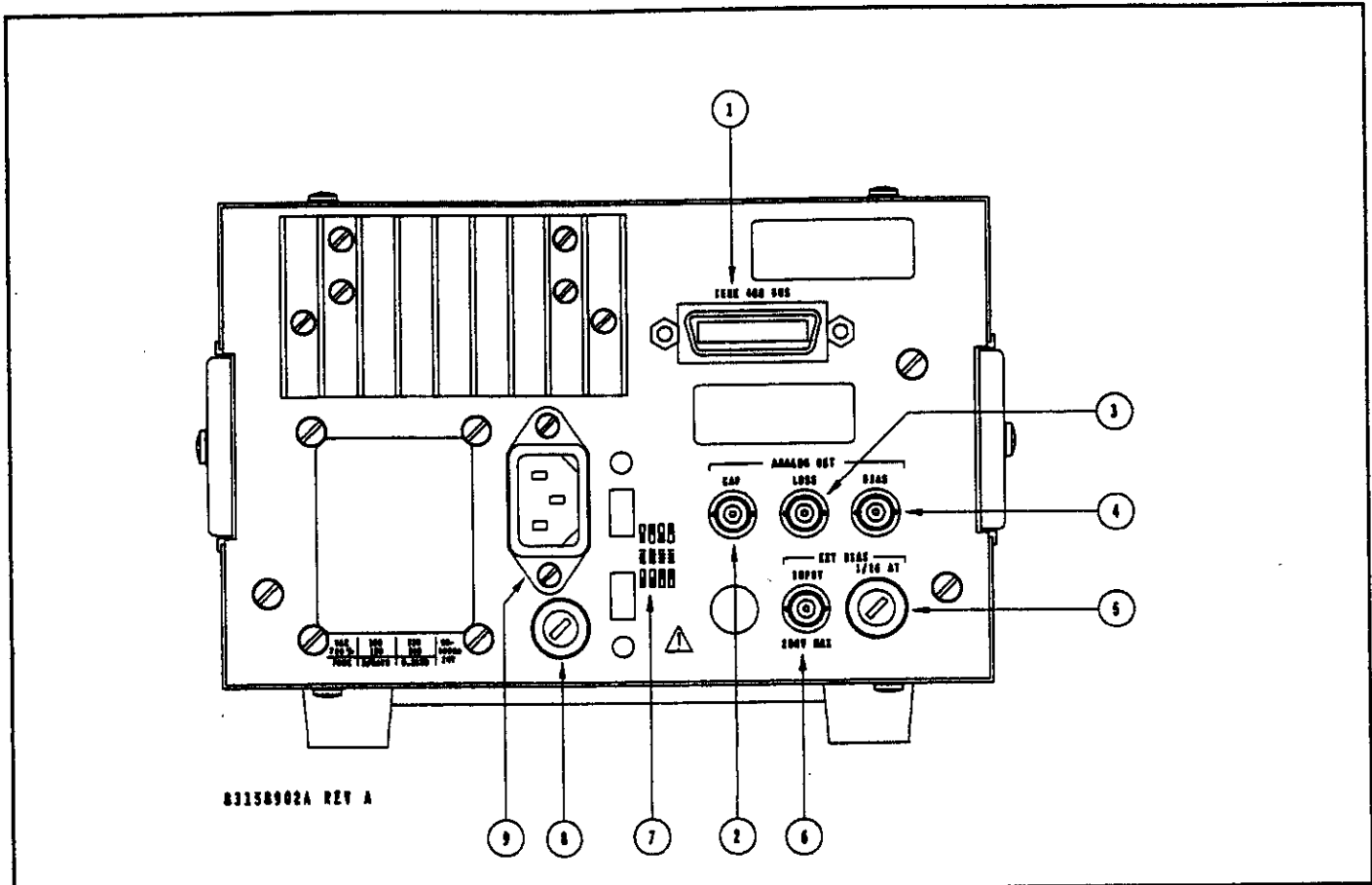

- | | |
|-----------------------------------|---|
| (1) IEEE-488 BUS connector. | Provides a means for connecting instrument into an automatic test system or to a personal computer. |
| (2) CAP connector. | Provides an analog voltage proportional to measured parallel capacitance (C_p) for application to a recorder or analog plotter. |
| (3) LOSS connector. | Provides an analog voltage proportional to measured conductance (G) for application to a recorder or analog plotter. |
| (4) BIAS connector. | Provides an analog voltage proportional to measured bias voltage for application to a recorder or analog plotter. |
| (5) EXT BIAS fuse. | Protects external bias circuit from overload. |
| (6) EXT BIAS INPUT connector. | Provides a means for connecting an external bias source to the instrument. |
| (7) Line voltage selector switch. | Provides a means to accommodate various ac supply voltages. |
| (8) Line fuse. | Protects instrument power circuits from overload. |
| (9) ac power receptacle. | Used to connect the ac power cord to the instrument ac power circuits. |

Figure 3-7. Rear Panel Connectors And Controls.

fuses are mounted on the rear-panel of the instrument.

3-28. The IEEE 488-BUS connector provides means for incorporating the instrument into an automatic test system. Bus operation of the instrument is covered in paragraph 3-64.

3-29. Three BNC-type ANALOG OUT connectors provide analog voltages that are proportional to measurement values of parallel capacitance, conductance, and bias. Since these voltages are proportional to measured values only, changing the instrument parameters to display computed values does not affect the analog outputs.

3-30. The BNC-type EXT BIAS INPUT connector provides means for connecting an external DC bias supply to the instrument. External bias voltage of either polarity may be applied up to a maximum of 200 volts. The control program will disconnect the external bias from the test specimen automatically if the measured value of the bias voltage exceeds approximately 200 volts. The bias circuit is protected by a 1/16 amp fuse adjacent to the connector.

3-31. The ac power receptacle provides a means for connecting ac power to the instrument. The ac power cord is supplied with the instrument. Line voltages of 100, 120, 220, or 240 volts, $\pm 10\%$ may be accommodated by adjusting the line voltage switches to the corresponding settings. The ac power circuit is protected by a fuse below the ac power receptacle.

3-32. LOCAL OPERATION.

3-33. **Applying AC Power.** Energize the instrument by setting the LINE switch to the ON position. The LINE indicator will light, and the instrument will perform a short power-up routine, consisting of the following:

- "Boonton Electronics" is displayed momentarily.
- "Program Code" with a six-digit firmware revision number is then displayed.
- The display is then restored to the front panel setup which was active at the time of power down.

3-34. **Selecting Measurement Modes.** The parallel capacitance (C_p), conductance (G) and external bias (EXT) modes are the primary measurement modes. The measurement of parallel capacitance and conductance is achieved by using phase sensitive detectors. Each detector extracts from the measurement signal the magnitude of the in-phase and quadrature components relative to the 1 MHz test level oscillator. The other functions in the CAPACITANCE and LOSS groups are calculated from the C_p and G values. Refer to Table 3-1. Rear panel CAP, LOSS and BIAS analog outputs are available to monitor the detected parallel capacitance and conductance of the test specimen and the

Table 3-1. Capacitance And Loss Formulas.

Capacitance Formulas

Series Capacitance:

$$C_s = C_p + \frac{G}{\omega^2 C_p}$$

Delta Capacitance:

$$\Delta C = C_x - C_{std}$$

Delta Percent:

$$\Delta\% = \frac{100\% (C_x - C_{std})}{C_{std}}$$

Loss Formulas

Parallel Resistance:

$$R_p = \frac{1}{G}$$

Series Resistance:

$$R_s = \frac{1}{G + \frac{1}{(\omega C_p)^2}}$$

Quality Factor:

$$Q = \frac{\omega C_p}{G}$$

Dissipation Factor:

$$D = \frac{G}{\omega C_p}$$

Operation

applied bias voltage.

3-35. In normal operation the measurement circuits are auto-ranged for maximum resolution. The optimum measurement range is determined by the control program based on the greater of the Cp and G values. Manual override of the auto-range selection can be achieved using special functions 11 through 15.

3-36. **Zeroing the Instrument.** For accurate measurements, the instrument should be zeroed whenever the test level is changed, the test connection configuration is altered, or when displayed data indicate significant C or G residue. To zero the instrument, proceed as follows:

a. If a test fixture and/or cables are to be used with the test specimen, connect the test fixture and/or cables to the instrument front-panel connectors.

b. Press the ZERO key, a "Meter Zero" message will be displayed, and one bar will appear after this message for each of the four ranges as they are zeroed. When zeroing has been completed, the display will return to normal operation.

3-37. **Extending Instrument Measurement Range.** The wide zeroing range (approximately 2000 pF) of the instrument provides a means for effectively increasing the measurement range. For example, if the instrument was zeroed with a 2000 pF capacitance applied to the test connectors, subsequent measurements made after this capacitor was removed would be effectively shifted by 2000 pF. Therefore, the measurement range becomes 0 to 4000 pF rather than ± 2000 pF. To extend the instrument range in this manner, proceed as follows:

a. Connect the capacitance value by which the range is to be shifted to the test connectors.

b. Zero the instrument.

c. Remove the test specimen from the test connectors.

d. Record the displayed capacitance as a standard value using special function 2.

e. Enable the ΔC mode.

3-38. **Applying External Bias.** The external bias supply can be set to any value up to a maximum of 200 volts. Either polarity may be used. To apply external bias to the test specimen, proceed as follows:

a. Connect the external bias source to the rear-panel EXT BIAS INPUT connector.

b. Turn on the external bias source and adjust its out-

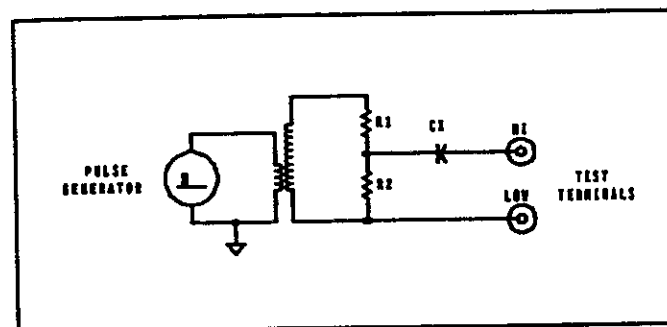

Figure 3-8. External Pulse Bias Circuitry.

put voltage to the desired value.

c. Press the BIAS EXT key. The LED in the key will light, and the measured value of the applied external bias will be shown on the left section of the instrument display.

d. To apply the external bias to the test specimen, press the BIAS ON key. The bi-color BIAS ON indicator will light to indicate that bias voltage is being applied to the TEST HI and DIFF HI connectors. If the absolute value of the bias voltage is 20 volts or less, the BIAS ON indicator will light green; if the bias voltage is above 20 volts, it will light red.

NOTE

If the measured value of the external bias exceeds approximately 200 volts, the instrument internal program will automatically disconnect the bias voltage from the TEST HI and DIFF HI connectors and "Error 2" will be displayed.

3-39. **Applying Pulse Bias.** The internal bias circuits of the instrument are bypassed for the 1 MHz test signal; therefore, they are unsuitable for application of fast pulses to bias the test specimen. Pulse slew rates faster than 20 V/ms may cause overshoot and ringing of the external bias circuitry. As a result, pulse bias with faster transition times must be applied through circuitry external to the instrument. A simple arrangement is shown in Figure 3-8. If the impedance of the pulse transformer secondary is low relative to R1, the test specimen may be considered to be in series with a resistance of $R1R2/(R1 + R2)$ ohms. This value need only be less than approximately 1/5 the reactance of the test capacitance at 1 MHz in order to have little influence on the phase detectors in the instrument. The ratio of the two resistors and their absolute values will depend on the pulse transformer and its load matching requirements, as well as the nature and magnitude of the pulse needed for bias. Additional information about pulse bias is available in Application Note IM-001. For a copy of the application note, contact Boonton Electronics.

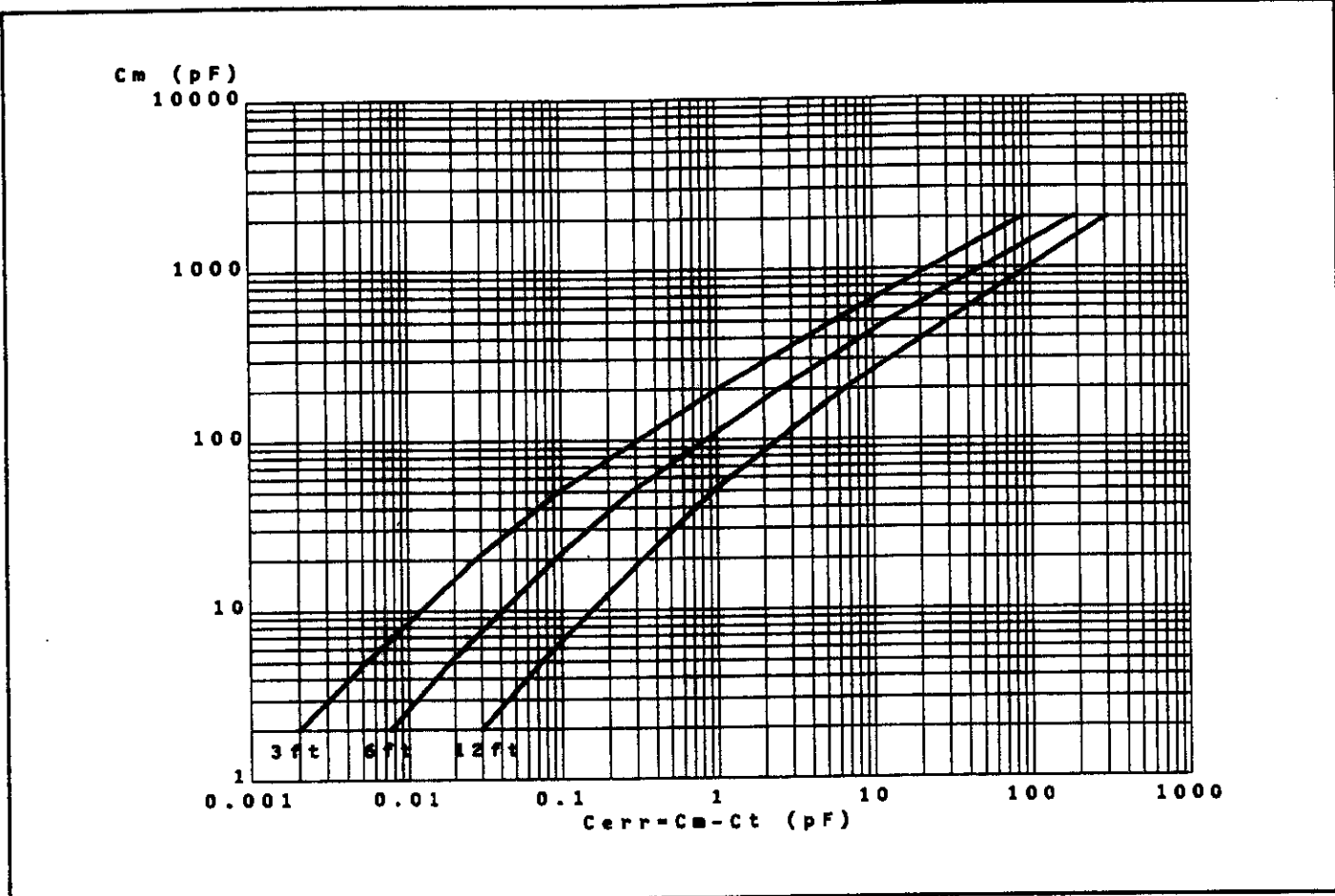

$$C_m/C = \frac{1 + j\omega Cr}{[\cos \beta l - \omega C Z_0 (\sin \beta l)]^2 \left[1 + \frac{\omega Cr (\cos \beta l) + (\sin \beta l) r/Z_0}{\cos \beta l - \omega C Z_0 (\sin \beta l)} \right]}$$

Where:

- C_m = the measured Capacitance
- C = the actual Capacitance
- βl = the electrical length of each line, in degrees
- Z_0 = the characteristic impedance of the line in ohms
- r = the equivalent resistance of the instrument from the TEST HI terminal to ground, as shown below:

140 ohms	2pF range
7 ohms	20 pF range
1 ohm	200pF and above

Figure 3-9. Capacitance Correction Curves.

Operation

3-40. Applying Internal Bias. Internal bias is programmable to ± 100 volts in increments of 1 millivolt for values of 20 volts or less, and in 10 millivolt increments for values above 20 volts. To program and apply internal bias, proceed as follows:

- a. Press the INT key. The LED in the key will light, and the current value of the internal bias will be shown on the left section of the display.
- b. If the displayed value is not the desired internal bias value, key in the desired value using the DATA ENTRY keypad. The left section of the display will then show the programmed internal bias.

NOTE

The instrument control program will automatically round off entries to the proper increment. For example, if a bias voltage of 29.124 volts is keyed in, the internal program will round off the entry to 29.12 volts.

- c. To apply the programmed internal bias to the TEST HI and DIFF HI connectors, press the BIAS ON key. The bi-color BIAS ON indicator will light green if the absolute value of the bias voltage is 20 volts or less, and it will light red if the absolute value is above 20 volts.

3-41. Remote Measurements And Cable Effects.

Remote measurement of capacitance over coaxial cables introduces a measurement error owing to the transmission line effect on the test voltage transmitted from the TEST LO connector, and on the received current at the TEST HI connector. For the Model 7200, the error is positive and its magnitude is shown in Figure 3-9 as a function of the measured capacitance, C_m , and cable length, βl . The error is not shown for the lowest range for 12-foot lengths of cable, as the capacitive loading of the TEST HI connector is excessive for lengths of RG-58/U cable greater than about 6.5 feet. It is imperative that the shields at both ends of the coaxial cables be tied together with a low-resistance, low-inductance strap for the correction curves and equation to be valid.

3-42. When calculating the electrical length in degrees of each of the two cables, it is necessary to know the velocity of propagation of the cable at 1 MHz. Samples of RG-58/U cable which were tested indicate a relative velocity of 63.5%. The impedance of the same cable measured 57.5 ohms at 1 MHz.

3-43. For short lengths of cable, a reasonable correction may be based on the effect of the series inductance of both lengths of cable. The measured capacitance, C_m , of a specimen will differ from the true capacitance, C_t , and the error will be seen as an apparent increase in capacitance in accordance with the following expression:

$$C_m = \frac{C_t}{1 - \omega^2 L C_t} = \frac{C_t}{1 - (X_L/X_{C_t})}$$

Or, if the true capacitance is required:

$$C_t = \frac{C_m}{1 + \omega^2 L C_m} = \frac{C_m}{1 + (X_L/X_{C_m})}$$

Where L = the combined series inductance of both lengths of connecting cables and the inductance of the sample (generally small with respect to the cable inductance. As an approximation, the inductance of RG-58/U cable with shields strapped at both ends) is about 0.091 $\mu\text{H}/\text{ft}$.

3-44. Programming Special Functions. The Model 7200 has many capabilities and functions that are accessed through use of the SPCL key. Special functions involve both operating features and instrument calibration functions. Some of the special functions allow the operator to modify the parameter value or state; others select a specific value or state when invoked. To prevent accidental loss of calibration data, access to special functions 50 through 59 can be restricted using the internal option/test switch. Table 3-2 lists the available special functions a detailed description of which is provided in paragraphs 3-45 through 3-59.

NOTE

If the selected special function number is out of range, or not accessible the display will show "Error 03". Access to special functions 1 through 9 is only permitted from the front panel and special functions 1 through 6, 8 and 9 are accessed by function mnemonic over the IEEE-488 interface. If the selected special function access is restricted by the internal option/test switch setting, the display will show "Error 18".

3-45. Selecting Test Level. The level of the 1 MHz test signal is programmable. Test levels of 15, 30, 50, or 100 millivolts may be programmed using special function 1. To program a test level, proceed as follows:

- a. Enter special function 1. The display will show "Test Level" followed by the currently active value.
- b. If the displayed test level value is not the desired value, key in the desired test level value and unit using the DATA ENTRY keypad.

NOTE

Test level values of 15, 30, 50, and 100 millivolts are the only valid test levels. If any other value is keyed in, the instrument program will automatically adjust the

selection to the nearest test level.

3-46. Selecting Capacitance Standard. To program the value of the capacitance standard used for ΔC or $\Delta\%$ capacitance measurements and for calibration of the instrument, proceed as follows:

a. Enter special function 2. The display will show "C Standard" followed by the currently active capacitance standard value.

b. If the displayed value is not the desired value, key in the desired value through the DATA ENTRY keypad. If the

capacitance standard value entry is out of range, the display will show "Error 05".

c. If the desired capacitance standard value is the same as the capacitance measurement, there is a short-cut method for entering the value. Simply depress the pF key alone in the DATA ENTRY keypad. The current value of the capacitance measurement will be copied to the capacitance standard value in a single keystroke.

3-47. Selecting Conductance Standard. To program the value of the conductance standard used for calibration of the instrument, proceed as follows:

Table 3-2. Special Function Codes.

Extended Functions:		Service Request Functions:	
0	Execute special functions 10, 20, 30 and 40	40	Normal operation, free-run display
1	Test Level display and entry	41	Disable SRQ interrupt
2	Capacitance Standard display and entry	42	Enable SRQ interrupt
3	Conductance Standard display and entry	43	Set SRQ mask when an error occurs
4	Capacitance Low Limit display and entry	44	Set SRQ mask and update display when measurement filter is complete
5	Capacitance High Limit display and entry	45	Set SRQ mask when capacitance measurement is within the high and low limit settings
6	IEEE-488 Bus Address display and entry	46	Set SRQ mask when capacitance measurement exceeds the high or low limit settings
7	End-of-string character display and selection	47	Set SRQ mask when zero or calibration is complete
8	Capacitance uncertainty display	48	Set SRQ mask when sweep is complete
9	Conductance uncertainty display		
Measurement Ranging Functions:		Automatic Calibration and Test Functions:	
10	Automatic selection	(Access to these functions can be restricted by setting the internal option switch position 6 to the open position.)	
11	Hold current measurement range	50	Calibrate detector offset
12	Set and hold 2.000 pF / 2.00 μ S range	51	Calibrate external bias offset
13	Set and hold 20.00 pF / 20.0 μ S range	52	Calibrate internal bias offset
14	Set and hold 200.0 pF / 200 μ S range	53	Calibrate full-scale capacitance
15	Set and hold 2000 pF / 2000 μ S range	54	Calibrate conductance phase
Internal Bias Ranging Functions:		55	Display internal temperature
20	Automatic selection	56	Display amplitude error due to temperature influence
21	Hold current bias range	57	Display phase error due to temperature influence
22	Set and hold 20.000 V range	58	Initialize instrument and erase all program locations
23	Set and hold 100.00 V range	59	Initialize software calibration variables
Measurement Filter Functions:			
30	Automatic selection		
31	Filter length = 1 measurement, no average		
32	Filter length = 2 measurements		
33	Filter length = 5 measurements		
34	Filter length = 10 measurements		
35	Filter length = 20 measurements		
36	Filter length = 50 measurements		
37	Filter length = 100 measurements		
38	Filter length = 200 measurements		
39	Filter length = 500 measurements		

Operation

a. Enter special function 3. The display will show "G Standard" followed by the currently active conductance standard value.

b. If the displayed value is not the desired value, key in the desired value through the DATA ENTRY keypad. If the conductance standard value entry is out of range, the display will show "Error 06".

3-48. Selecting Capacitance High and Low Limits.

Special functions 4 and 5 provide a convenient means for determining which test specimens of a batch being tested fall outside acceptable capacitance limits. Any capacitance low limit within the instrument range can be selected using special function 4; any capacitance high limit within the instrument range can be selected using special function 5. When limit values have been set, measured capacitance values that are over-limit will cause a bracketed, upward-pointing arrow to appear in the right section of the display in place of the normal measured value. Similarly, measured capacitance values that are under-limit will cause a bracketed, downward-pointing arrow to appear. To select and set limit values, proceed as follows:

a. Enter special function 4. The instrument display will show "Low Limit" followed by the capacitance low-limit value. If the displayed value is not the desired value, key in the desired low-limit value through the DATA ENTRY keypad. If the selected capacitance low limit is out of range, the display will show "Error 07".

b. Enter special function 5. The instrument display will show "High Limit" followed by the capacitance high-limit value. If the displayed value is not the desired value, key in the desired high-limit value through the DATA ENTRY keypad. If the selected capacitance high limit is out of range, the display will show "Error 08".

3-49. Selecting IEEE-488 Bus Address. Entering SPCL 6 enables display and entry of the IEEE-488 bus address assigned to the instrument. Any value from 0 to 30 may be entered. In applications using the PLOT function, address 30 is reserved for the plotter and should not be used for the

instrument. If the selected address is out of range, the display will show "Error 09".

3-50. Selecting End-of-string Character. Entering SPCL 7 enables display and selection of end-of-string characters for IEEE-488 bus operation. This function can only be accessed from the front panel. When the special function is entered, the display will show the current end-of-string selection. If another selection is required, press the SHIFT/SCROLL key to scroll to the desired selection and press any function key or the ENTER key to exit. Refer to Table 3-3 for end-of-string character choices.

3-51. Selecting Capacitance Uncertainty Display.

Special function 8 provides a convenient means for displaying the worst-case uncertainty of the capacitance measurement. The complete specified accuracy, including temperature influence, is calculated and displayed along with the actual capacitance measurement. To select the capacitance uncertainty display mode, proceed as follows:

a. Enter special function 8. The instrument display will show the capacitance measurement value on the left half of the display followed by the calculated worst-case uncertainty on the right half of the display. No loss or bias information is displayed in this mode. To clear the mode simply depress any function key.

3-52. Selecting Conductance Uncertainty Display.

Special function 9 provides a convenient means for displaying the worst-case uncertainty of the conductance measurement. Like the special function 8, the complete specified accuracy, including temperature influence, is calculated and displayed along with the actual conductance measurement. To select the conductance uncertainty display mode, proceed as follows:

a. Enter special function 9. The instrument display will show the conductance measurement value on the left half of the display followed by the calculated worst-case uncertainty on the right half of the display. No capacitance measurement is displayed while this mode is active. To clear the mode simply depress any function key.

Table 3-3. End-of-string Character Selections.

Display Message (SPCL 7)	Listen Termination	Talk Termination
End Of String CL/CL	CR and LF or EOI	CR and LF and EOI
End Of String C/CL	CR or EOI	CR and LF and EOI
End Of String C/C	CR or EOI	CR and EOI
End Of String L/L	LF or EOI	LF and EOI
End Of String EOI	EOI	EOI

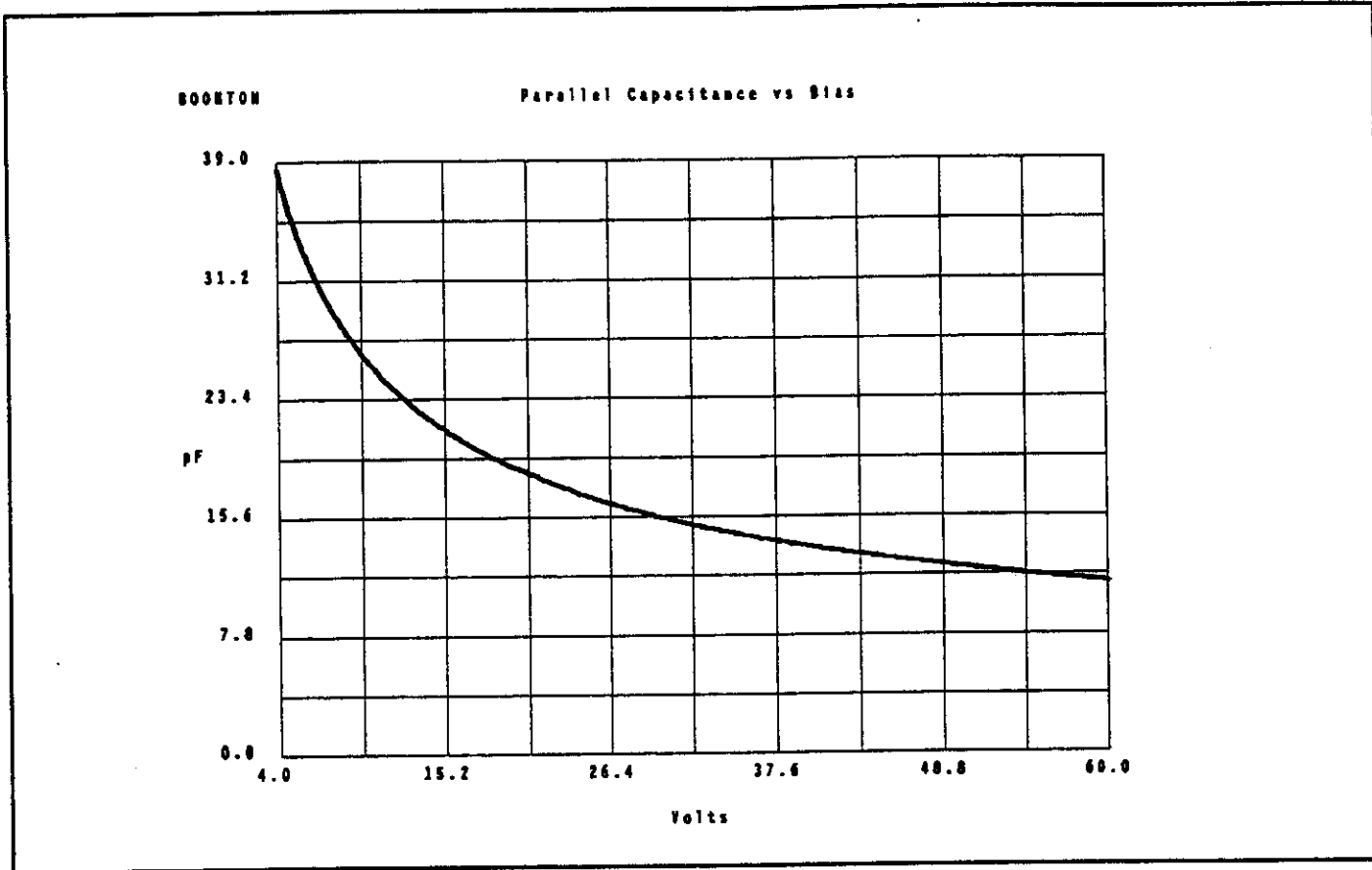

Figure 3-10. Typical Plot of a Varactor Diode.

3-53. Selecting Measurement Ranges. Special functions 11 through 15 select and hold various measurement ranges. Entering SPCL 10 selects automatic ranging, and entering SPCL 11 holds the current instrument range. Entering SPCL 12, 13, 14, or 15 sets and holds the respective 2, 20, 200, or 2000 pF/ μ S measurement range. Note that special function 10 is also executed automatically when SPCL 0 is entered. If a specific range is selected and the measurement value is overranged, the instrument display will show a bracketed, upward-pointing arrow in place of the normal numerical value. Also if the ZERO key is pressed, only the selected range is zeroed.

3-54. Selecting Internal Bias Ranges. Special functions 21 through 23 select and hold various internal bias ranges. Entering SPCL 20 enables automatic bias range selection; this special function is also executed automatically when SPCL 0 is entered. Entering SPCL 21 holds the current internal bias range. Entering SPCL 22 or 23 will set and hold the respective 20 or 100 volt internal bias range. When the 20 volt range is held, bias voltage entries greater than 20 volts are not permitted and will cause "Error 01" to be displayed.

3-55. Selecting Measurement Filter Lengths. The in-

strument can average a number of measurements, ranging from 1 to 500, to provide a more stable measurement display. The number of measurements averaged for each display update is a function of filter length. The choice of filter length involves a compromise between stability and measurement speed. Generally, the longer the filter length, the more stable the measurement readings; however, the measurement time increases directly with filter length. Filter length is selectable using special functions 31 through 39. Entering SPCL 30 enables automatic selection; this special function is also executed automatically when SPCL 0 is entered. Entering SPCL 31 selects one measurement per display (no averaging). Entering any special function from SPCL 32 through SPCL 39 selects one of the available measurement filter lengths, ranging from 2 to 500 measurements per average. In the automatic mode (SPCL 30), the measurement filter selection is determined by the test level selection. For test levels of 100, 50, 30 and 15 mV the respective filter lengths are 5, 10, 20 and 50 measurements per average.

3-56. Selecting SRQ Interrupt Modes. Special functions 40 through 48 enable the operator to configure the SRQ interrupt mode for IEEE-488 bus operation. The data in the serial poll status byte is determined by the SRQ mask con-

Operation

figuration. Entering SPCL 40 selects normal operation, with all mask bits inactive and SRQ interrupt disabled. This special function is executed automatically when SPCL 0 is entered. Entering SPCL 41 disables the SRQ interrupt leaving mask bits unchanged; entering SPCL 42 enables the SRQ interrupt. The remaining special functions set the SRQ mask for specific operating conditions. Refer to Paragraph 3-73 for further information on using service request.

3-57. Selecting Automatic Calibration Modes. These special functions are used for automatic calibration and are not used in normal operation.

3-58. Selecting Temperature Display Modes. Measurement values will be influenced by temperature, affecting accuracy. The instrument has a built-in temperature sensor to measure internal temperature. Special function 55 may be executed to obtain a display of this temperature, and special functions 56 and 57 may be executed to obtain a display of amplitude error and phase error, respectively, due to temperature influence.

3-59. Selecting Memory Initialization Functions. Entering SPCL 58 initializes the instrument and erases all program locations. Entering SPCL 59 sets software calibration variables to nominal values in preparation for recalibration of the instrument.

CAUTION

Selecting special function 59 sets calibration variables to nominal and places the instrument in an uncalibrated condition. Recalibration of the instrument is the only method of restoring calibration data. Use of this function is only recommended during repair and recalibration of the instrument. See paragraph 3-62 for instructions on how to restrict access to this function.

3-60. Store And Recall Program Operation. The Model 7200 can store up to 99 distinct front-panel setups in nonvolatile memory. To select a panel setup for storage or recall, proceed as follows:

- a. Press the PRGM key, the instrument display will show "prgm" followed by the active program number.
- b. Select the desired program number using the DATA ENTRY keypad, and press the ENTER key. If the selected program number is out of range the display will show "Error 04".
- c. To store the current panel setup as the selected program, press the STORE key. To recall a previously stored program with the selected program number from memory, press the RECALL key. Program location 99 is a recall-only

location that contains the preset conditions listed in Table 2-1. Attempting to store at location 99 will result in "Error 11" being displayed.

3-61. Using The SETUP Mode. The Model 7200 is capable of making a series of test specimen measurements as bias is varied and formatting the test data for transmission to a HPGL compatible plotter. Figure 3-10 shows a typical plot. The SETUP mode is divided into sweep parameter functions and plot parameter functions. The sweep parameter functions allow the operator to configure the sweep range and increment values. The plot parameter functions allow the operator to format a plot of the sweep data. To select the sweep parameter functions proceed as follows:

- a. Press the SETUP key, the instrument display will show "Bias Start" followed by the voltage value defining the beginning of the sweep.
- b. Select the desired bias start voltage using the DATA ENTRY keypad. If the selected voltage is out of range the display will show "Error 09".
- c. After the desired voltage is selected, press the ENTER key. The instrument display will show "Bias Stop" followed by the voltage value defining the end of the sweep.
- d. Select the desired bias stop voltage using the DATA ENTRY keypad. If the selected voltage is out of range the display will show "Error 09".
- e. After the desired voltage is selected, press the ENTER key. The instrument display will show "Bias Step" followed by the voltage value defining the size of the sweep increment.
- f. Select the desired step voltage using the DATA ENTRY keypad. If the selected voltage is out of range the display will show "Error 09".

3-62. The portion of the SETUP mode that selects the sweep parameters is now complete. In order for the instrument to generate plots using the PLOT key, the plot parameter functions of the SETUP mode should be selected as follows:

- a. After the desired bias step voltage is selected, press the ENTER key. The instrument display will show one of the plot mode menus shown below.

"Plot Cp vs Bias"
 "Plot Cs vs Bias"
 "Plot ΔCp vs Bias"
 "Plot ΔCs vs Bias"
 "Plot Δ%p vs Bias"
 "Plot Δ%s vs Bias"
 "Plot G vs Bias"

- "Plot Rp vs Bias"
- "Plot Rs vs Bias"
- "Plot D vs Bias"
- "Plot Q vs Bias"

- "Auto Scale X Axis"
- "Decade Scale X Axis"
- "Full Scale X Axis"
- "Fixed Scale X Axis"

b. Scroll to the desired plot mode using the SHIFT/SCROLL key and make the selection using the ENTER key.

d. Scroll to the desired X axis scale mode using the SHIFT/SCROLL key and make the selection using the ENTER key.

c. After the ENTER key is pressed. The instrument display will show one of the following X axis scale modes:

e. After the ENTER key is pressed. The instrument display will show one of the following Y axis scale modes:

Table 3-4. SETUP Mode Selections.

Sweep Parameter Functions			
Display Message	Description	Argument Range	Bus Mnemonic
Bias Start 0.000 V	Start value for internal bias sweep	± 100 volts	XL
Bias Stop 0.000 V	Stop value for internal bias sweep	± 100 volts	XR
Bias Step 0.000 V	Step size value for internal bias sweep	0 to 100 volts	XS
Plot Parameter Functions			
Display Message	Description	Argument Code	Bus Mnemonic
Plot Mode Menu Selection			PM
Plot Cp vs Bias	parallel capacitance vs bias	0	
Plot Cs vs Bias	series capacitance vs bias	1	
Plot ΔCp vs Bias	relative parallel capacitance (ΔC) vs bias	2	
Plot ΔCs vs Bias	relative series capacitance (ΔC) vs bias	3	
Plot Δ%p vs Bias	relative parallel capacitance(Δ%) vs bias	4	
Plot Δ%s vs Bias	relative series capacitance (Δ%) vs bias	5	
Plot G vs Bias	conductance vs bias	6	
Plot Rp vs Bias	parallel resistance vs bias	7	
Plot Rs vs Bias	series resistance vs bias	8	
Plot D vs Bias	dissipation factor vs bias	9	
Plot Q vs Bias	quality factor vs bias	10	
X Axis Menu Selection			XA
Auto Scale X Axis	scale X axis to fill 100% of axis with data	0	
Decade Scale X Axis	scale X axis to next available decade value	1	
Full Scale X Axis	scale X axis to full range of bias supply	2	
Fixed Scale X Axis	hold X axis scale at previous value for multiple data plots on the same grid	3	
Y Axis Menu Selection			YA
Auto Scale Y Axis	scale Y axis to fill > 80% of axis with data	0	
Decade Scale Y Axis	scale Y axis to next available decade value	1	
Full Scale Y Axis	scale Y axis to full range of measurement	2	
Fixed Scale Y Axis	hold Y axis scale at previous value for multiple data plots on the same grid	3	

- "Auto Scale Y Axis"
- "Decade Scale Y Axis"
- "Full Scale Y Axis"
- "Fixed Scale Y Axis"







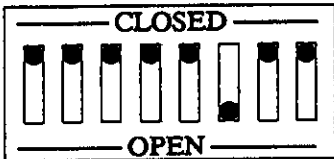

g. Scroll to the desired Y axis scale mode using the SHIFT/SCROLL key and make the selection using the ENTER key.

3-63. The portion of the SETUP mode that determines the plot parameters is now complete. The SETUP mode is automatically terminated after the last plot parameter mode is

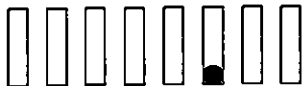
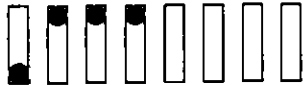
selected.

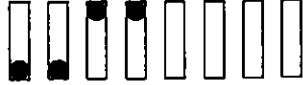
3-64. **Setting The Option/Test Switch.** The internal option/test switch provides a means of selecting optional configurations and executing test functions. Gaining access to the switch requires that the top cover be removed. The option/test switch consists of eight separate switches. Table 3-5 lists the individual switches and their functions. Switch positions 1 through 4 are recognized on power-up and when the LCL/INIT key is pressed. Switch positions 5 and 6 are recognized immediately.

Table 3-5. Option/Test Switch Selections.

	Factory settings
	Reserved
	Access to special functions 50 - 59 restricted
	Lamp test mode enabled
	Nominal phase calibration mode enabled
	Phase detector linearity test mode enabled
	Keyboard test mode enabled
	DAC test mode enabled
	Erase memory (SPCL 58) and set all calibration values to nominal (SPCL 59) at power-up and when the INIT/LCL key is pressed

3-65. Error Messages. If invalid data entries are attempted during programming of the instrument, an error message will be displayed in the applicable display section. The error message consists of "Error" followed by an error code number. Error codes are defined in Table 3-6.

3-66. IEEE-488 BUS OPERATION.

3-67. General. All front-panel controls, with the exception of the LINE switch, LCL/INIT key, PLOT key and end-of-string selection (SPCL 7) can be programmed from the IEEE-488 bus. To operate the instrument using the IEEE-488 bus, first program the instrument as follows:

- a. Enter the bus address assigned to the instrument using special function 6. Refer to paragraph 3-49.
- b. Set the end-of-string character(s) using special function 7. Refer to paragraph 3-50.

3-68. Entering Remote Mode. The Model 7200 is placed in the remote state by addressing it as a listener with remote enable (REN) true. In the remote state, the keyboard is disabled, except for the LCL/INIT key and the LINE switch, and the REM annunciator is illuminated.

3-69. Returning To Local Mode. The instrument may be returned to local mode as follows:

- a. The LCL/INIT key is pressed, providing that local

lockout (LLO) is not active.

- b. The go-to-local (GTL) bus command is sent.
- c. Remote enable (REN) is set false.

NOTE

The instrument must be placed in the remote state if it is to respond to data messages.

3-70. Talk Operation. The instrument may be addressed as a talker without regard for remote/local mode. When the talker state is activated by the system controller, the Model 7200 sends a character string which is determined by the current talk mode. One of seven different talk modes is selected by sending the appropriate mnemonic with the Model 7200 addressed as a listener. The selected mode will remain in effect until it is changed. The talk modes are defined below.

- a. **Talk Status (TS).** In the TS mode, the active error code of the instrument is returned. If there is no error, the value returned is zero. After the error code is returned the error is automatically cleared.

- b. **Talk Value (TV).** In the TV mode, the current value of the most recently selected function is returned. All level values returned are expressed in volts and all resistance values returned are expressed in ohms.

Table 3-6. Error Codes.

01	Internal bias entry out of range	51	Calibration error: full-scale adjustment at 30 mV test level
02	External bias measurement out of range	52	Calibration error: full-scale adjustment at 50 mV test level
03	Special function entry out of range	53	Calibration error: full-scale adjustment at 100 mV test level
04	Program location entry out of range	54	Calibration error: phase adjustment at 15 mV test level
05	Capacitance standard entry out of range	55	Calibration error: phase adjustment at 30 mV test level
06	Conductance standard entry out of range	56	Calibration error: phase adjustment at 50 mV test level
07	Capacitance low limit entry out of range	57	Calibration error: phase adjustment at 100 mV test level
08	Capacitance high limit entry out of range	58	Calibration error: external bias offset
09	Sweep setup mode entry out of range	59	Calibration error: Internal bias offset on 20 V range
10	Address entry out of range	60	Calibration error: internal bias offset on 100 V range
11	Recall only program	61-99	Reserved
12	Requested program is empty		
13	Illegal unit selection		
14	Data keyboard entry overflow		
15	Nonexistent IEEE-488 mnemonic		
16	IEEE-488 input buffer overflow		
17	Illegal program string format		
18	Special function entry is restricted		
19-49	Reserved		
50	Calibration error: full-scale adjustment at 15 mV test level		

c. **Talk Measure (TM).** In the TM mode, the current measurement values of parallel capacitance (Cp), conductance (G), and bias are returned. The numbers are separated by an ASCII ";". Note that the bias value returned is strictly a measurement. Therefore, when the INT function is enabled, the bias value returned is a measurement of the internal bias supply. Another advantage of the TM mode is that the values returned have extended resolution to 20,000 counts, full scale. The extended resolution is derived by averaging multiple A/D readings. Refer to paragraph 3-55 for more information on setting the averaging filter.

Example: "20.111,0.342,25.23"

d. **Talk Display (TD).** In the TD mode, the front-

panel display contents are sent as a 20-character string. Control characters such as ↑, ↓, Δ and Ω are replaced with a space.

Example: " 0.3uS 20.11pF "

e. **Talk Program (TP).** In the TP mode, a compressed parameter string of 169 ASCII characters, the last of which is an ASCII (\$), is returned. This string can be sent back to the instrument at any time to restore the exact state of all functions and settings which defined it, but it must be sent as a complete string without alteration. The string is recognized when the (\$) character is encountered in the input buffer. While this form provides a compact and fast method to save and restore all settings, it bypasses much of the error

Table 3-7. IEEE-488 Bus Mnemonics.

Functions With Numerical Arguments:		Miscellaneous Mnemonics:	
BI	Internal Bias (-100.00 to +100.00 V)	ZR	Zero
TL	Test Level (15, 30, 50 and 100 mV)	BO	Bias on
RC	Capacitance Standard (-9999 to +9999 pF)	BX	Bias off
RG	Conductance Standard (-9999 to +9999 μS)	SW	Bias sweep on
SP	Special Function (0 to 99)	CL	Clear errors and disable bias sweep
PG	Program Location (0 to 99)	RE	Recall front panel setup from program location
AD	IEEE-488 Bus Address (0 to 30)	ST	Store front panel setup to program location
LL	Capacitance Low Limit (-9999 to +9999 pF)		
HL	Capacitance High Limit (-9999 to +9999 pF)		
XL	Bias Start (-100.00 to +100.00 V)		
XR	Bias Stop (-100.00 to +100.00 V)		
XS	Bias Step (0 to 100.00 V)		
PM	Plot Mode Selection (0 to 10)		
XA	X Axis Scale Selection (0 to 3)		
YA	Y Axis Scale Selection (0 to 3)		
Functions Without Numerical Arguments:		Bus Command Mnemonics:	
BE	External Bias	TS	Set talk mode to talk status byte
LG	Loss, G	TV	Set talk mode to talk value of current measurement
LR	Loss, R	TM	Set talk mode to talk capacitance, conductance, and bias measurement values
LQ	Loss, Q	TD	Set talk mode to talk current display contents
LD	Loss, D	TP	Set talk mode to talk current front panel setup in stored program format
CP	Capacitance, Parallel	TG	Set talk mode to talk plot graph in HPGL format
CS	Capacitance, Series	TC	Set talk mode to talk calibration values
DC	Delta Capacitance	ID	Set talk mode to talk instrument identification
DP	Delta Percent	IM	Set immediate trigger mode (free-run)
CU	Capacitance Uncertainty Display Mode	WT	Set wait-for-trigger mode
GU	Conductance Uncertainty Display Mode	TR	Trigger a measurement
		BL	Blank display and keyboard except for bus legends
		UD	Update display and restore normal display mode
Unit Mnemonics:			
VO	Volts		
MV	Millivolts		
PF	Picofarads		
US	Microsiemens		

control and must be used with caution.

f. **Talk Plot Graph (TG).** In the TG mode, plotter graph data is sent as a variable length string of ASCII characters in HPGL format. This is the same graph data which would be generated using the PLOT key. When the instrument is commanded to talk in this mode, the display will contain the message "Generating Plot Data" while the sweep data is converted to HPGL format. After conversion the entire talk buffer is returned.

Example: "IN;SC-20,100,-20,100;SP1;PA0,0;" etc.

g. **Talk Identification (ID).** In the ID mode, the instrument model and program code are sent as a string of 31 ASCII characters.

Example: "Model 7200 Program Code c900531"

3-71. Program Function Mnemonics. Each front-panel function is assigned a two-character mnemonic. Programming a mnemonic, followed by numeric arguments and unit values, if applicable, is analogous to manual front-panel operation. Additionally, other program mnemonics are used for functions that are only applicable in remote operation. Program function mnemonics are described in Table 3-7.

3-72. Triggered Operation. In the remote state, the Model 7200 can be operated in the immediate mode (IM) or the wait-for-triggered mode (WT). The immediate mode is the default condition and results in the immediate execution of received commands. The wait-for-trigger mode causes the execution of data to be deferred until receipt of a trigger. After the WT mnemonic is received, subsequent measurements will be delayed until one of the following events occurs:

- a. A group-execute-trigger (GET) command is received.
- b. The TR mnemonic is interpreted in a received string.

- c. Any mnemonic following (IM) is interpreted.

NOTE

Go-to-local or device clear (DCL) restores the immediate mode.

3-73. Using Service Request. The Model 7200 can be configured to set service request (SRQ) true when it is in the remote mode and a selected condition has occurred. SRQ informs the bus controller that the special event has occurred. SRQ can be enabled or disabled using SPCL 42 and 41, respectively. Events that generate service requests are selected using SPCL 43 through SPCL 48. The system controller must be programmed to respond to SRQ true. When the instrument SRQ is set true, the instrument expects the bus controller to perform a serial poll to determine which device on the bus set SRQ true and to determine what event has occurred. If the Model 7200 is the requesting device, it will respond to the serial poll with multiple bits that represent different status and error conditions. These conditions are individually maskable, as shown in Table 3-8. The SRQ line will be cleared by conducting a serial poll, talking status using the talk status mode (TS), sending the clear command (CL) or pushing the CLR key.

3-74. Bus Command Responses. IEEE-488 bus commands are sent by the system controller to all devices on the bus (Universal Command Group) or to the addressed devices (Addressed Command Group). The responses of the Model 7200 are listed in Table 3-9.

3-75. Number formatting. Number formatting rules are as follows:

- a. Fixed or floating formats are accepted.
- b. The optional + or - may precede the mantissa and/or the exponent.
- c. The optional decimal point may appear at any posi-

Table 3-8. Serial Poll Status Byte Decoding.

Hex	Decimal	Description
01	01	Status bit set when an error occurs
02	02	Status bit set when the measurement filter is complete
04	04	Status bit set when the capacitance measurement is within the high and low limit settings
08	08	Status bit set when the capacitance measurement exceeds the high or low limit settings
10	16	Status bit set when a zero or calibration routine is complete
20	32	Status bit set when a sweep is complete
40	64	Status bit set when a service request is generated

tion within the mantissa. A decimal point in the exponent is ignored.

- d. The optional "E" for exponent may be upper or lower case.
- e. ASCII characters having hexadecimal values of 0 to 23 and 25 to 2B are ignored.

3-76. Data String Syntax. Program string syntax rules are as follows:

- a. The programming sequence is in natural order, that is, a function mnemonic is sent first, followed by the argument and units, if applicable.
- b. ASCII characters having hexadecimal values of 0 to 23 and 25 to 2B are ignored. The ASCII "S" (hexadecimal 24) is reserved. Lower case characters are automatically converted to upper case.
- c. A function mnemonic sent without a following argument will make the specified function active.
- d. Multiple numeric entry values must be delimited by a mnemonic. No delimiter is needed between mnemonics.
- e. The programmable data string may not exceed 512 characters and may be terminated with LF, CR, and/or EOI. Refer to paragraph 3-50.
- f. Interpretation of the data string does not begin until the end-of-string character(s) are received.
- g. If units are not specified for any argument, default units are automatically appended. The functions SPCL and PRGM always use default units.

h. If a unit mnemonic is sent without a corresponding argument, the display will reflect the change, provided that:

- 1. The units are appropriate to the active function; otherwise, an error will result.
- 2. The display is enabled.
- 3. The display can accommodate the rescaled result.

i. Errors are detected during interpretation. The occurrence of an error will cause display of the error code if the display is enabled. The instrument will send SRQ if enabled by special functions 42 and 43. Any subsequent arguments sent to the instrument will be ignored until the error is cleared.

3-77. Selecting Menu Modes Using The Bus. Some of the SETUP mode functions are menu-type functions. Since there is no provision for scrolling the menu selections via the bus interface, selecting the desired menu mode is achieved by programming the function mnemonic followed by an argument code. Table 3-4 lists the SETUP mode functions and the argument codes to select the various menu modes.

3-78. Data String Examples. The following are examples of typical programming strings in HP BASIC to set the internal bias voltage to 21.5 volts. All three examples achieve the same result.

- a. OUTPUT 718; "BI 21.50 VO"
 - b. OUTPUT 718; "BI 21.5E3 MV"
 - c. OUTPUT 718; "BI 21.5000"
- (volts is assumed if unit is not specified.)

Table 3-9. IEEE-488 Bus Command Responses.

Commands	Instrument Response
Universal Command Group:	
Device Clear (DCL)	Clear errors
Local Lockout (LLO)	Disable LCL/INIT key
Serial Poll Enable (SPE)	Sets talk mode for poll response
Serial Poll Disable (SPD)	Restores talk mode before poll
Addressed Command Group:	
Selective Device Clear (SDC)	Same as device clear (DCL)
Go to Local (GTL)	Sets LOCAL mode
Group Execute Trigger (GET)	Triggers a measurement
All Others:	Ignored

SECTION IV THEORY OF OPERATION

4-1. General Description. The Model 7200 is a versatile microprocessor controlled Capacitance Meter useful for measuring both semiconductors and passive components. The internal 1.0 MHz test signal is programmable between 15 mV and 100 mV levels for optimum measurements on different types of devices. A programmable internal DC bias supply is convenient for performing measurements while biasing the device under test. Measurements from 0 to 2000 pF are provided in four decade ranges. A unique feature of the instrument is the ability to measure and display the loss component of the device in addition to the capacitance value. Calculated values of a number of associated parameters are also displayed or recorded when required. A variable averag-

ing function enables setting optimum conditions for settled readings or speed. Plot capability is fully supported and all functions of the unit are controllable over the standard IEEE-488 interface bus. An automatic zeroing function is incorporated and the unit may be easily calibrated using external standards.

4-2. The functional blocks of the model 7200 are shown in Figure 4-1. A 1 MHz crystal stabilized oscillator supplies a signal to provide the test level required at the front panel measuring terminals. An auxiliary output of the oscillator provides the reference signal for the phase sensitive detector circuitry on assembly A5A2. Amplifier assembly A5A3 in-

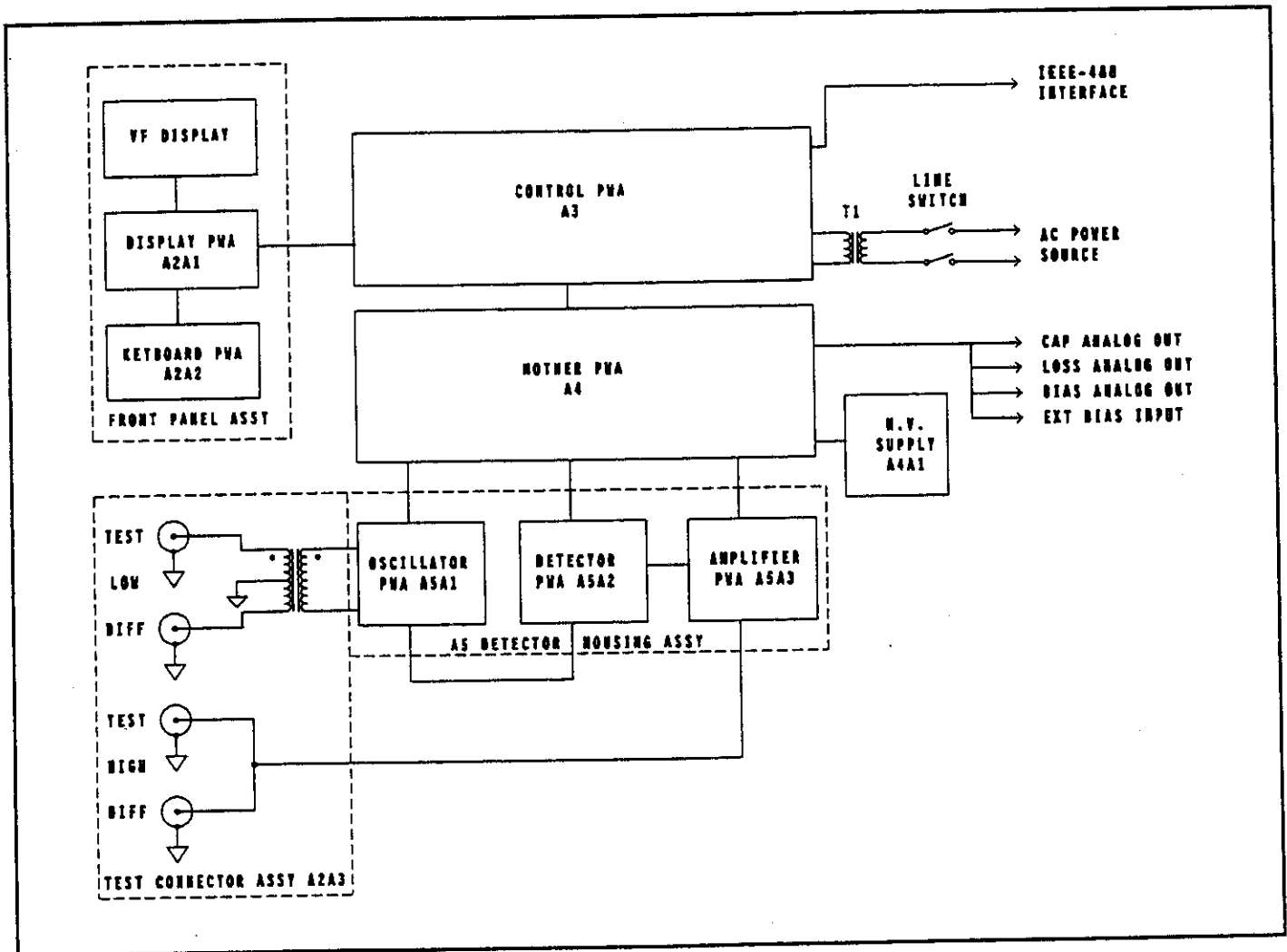

Figure 4-1. Functional Block Diagram.

Section 4

creases the output signal from the measuring terminals to an amplitude suitable for operation of the synchronous detectors. Ranging circuits that provide four decade ranges are located on the amplifier assembly. The control assembly A3 contains a microprocessor and associated integrated circuits which perform the logic functions and IEEE bus interface operation. The main instrument power supply is also located on A3. The power transformer, AC power input connector, and fuse are located on the rear panel. The variable internal bias supply is mounted on the mother board assembly and is designated A4A1. The keyboard assembly A2A2 provides manual operation of the instrument and control over various display options implemented by the vacuum fluorescent panel on display assembly A2. Analog outputs for plotting operations are located on the rear panel. The mother PC board, A4, contains buffering and control circuitry for the bias supply but functions primarily as an interconnection assembly.

4-3. Detailed Description. The basic measuring scheme of the 7200 is illustrated in Figure 4-2.

4-4. 1 MHz Oscillator Circuitry. The TTL output of 1 MHz oscillator, Y1, mounted on A5A1 is filtered by a multi-section low pass filter network to provide a sinusoidal signal with low harmonic content. The output is sampled by diode, CR3, and fed to a leveling circuit consisting of U2, Q1, Q2, and Q3. U2 amplifies the feedback signal to control the leveling amplifier Q2 through the current limiting devices, Q1 and Q3. Two resistive pi-section attenuators are employed to set the 1 MHz signal to the proper test level. The attenuator sections are activated as required by relays K1 and K2. The first section consisting of R12, R13, and R14 provides a 6 dB reduction when switched into the signal path. The second section (R18, R19, R20) provides 10 dB. With proper switching, overall attenuation values of 0, 6, 10, and 16 dB are available. These are used to provide the selected test level of 100, 50, 31.6, or 15.8 millivolts. Transformer T1 on A5 provides a matched balanced output to drive the step-down transformer located at the measuring terminals of A2A3 on the front panel input assembly. A secondary output (at J4 on A5A1) preceding the attenuator sections supplies the reference signal to drive the phase sensitive detector circuitry on assembly A5A2. Regulator U1 on the oscillator assembly provides the +5 volts required for the oscillator module.

4-5. Front Panel Test Terminals. The step-down transformer T1 on A2 provides an approximate 100:1 impedance ratio presenting an output impedance of approximately 0.25 ohms at the LO terminals on the front panel. The 1 MHz signals applied to the TEST and DIFF terminals are equal in amplitude and displaced in phase by 180 degrees.

4-6. The output signals from the Device Under Test (DUT) are present at the HI terminals which are connected in parallel. They are fed to the amplifier circuits on A5A3. The

internal or external DC bias voltage is applied to the DUT at these terminals.

4-7. Input Ranging Circuitry. Preceding the amplification process, the output signal from the DUT is applied to one of four ranging circuits consisting of an inductive and a capacitive element in a series resonant configuration. The current flowing through the resonant circuit to ground is directly proportional to the susceptance of the specimen at the test terminals. The output for each range is developed across the capacitive element of the LC combination. The function of the ranging circuitry is to provide a common range of signal amplitudes for each decade of capacitance. The ranging networks are switched into the signal path by means of reed relays (K1-K3) at the input side and diode switching networks at the output (CR8-CR11). The two highest ranges share a common inductor, L5, on A5A3. K3, therefore is activated on both the 200 pF and 2000 pF ranges.

4-8. Input Amplifier Circuitry. The output of the ranging circuits is conditioned by diode clamps CR12 and CR13 at the input to the source follower, Q5. A feedback pair, Q1 and Q2, provides amplification of the signal. The gain is set by resistors R11 and R13 to be about 11:1. CR14 operates as a clamping device. R14 and R15 comprise a 10 dB resistive attenuator which is switched into the signal path when the 100 mV or 50 mV test level is in use. U1 on A5A3 is an analog switch device performing this function. Q3 and Q4 are a similar feedback pair for further amplification.

4-9. The signal travels to A5A2 where a switchable 6 dB attenuator (R4, R5) provides a function similar to that noted above for the 10 dB unit. It is switched into the signal path on the 31.6 mV and 100 mV ranges. U1 on A5A2 is the switching element. The purpose of the attenuator modules is to minimize the dynamic range required of the amplifier chain at the various test level settings. Q1 and Q2 in this section are an additional feedback pair gain block. A thermistor, RT1, has been added in the feedback loop to provide compensation for gain variations with changes in ambient temperature. R25 provides a coarse phase calibration adjustment for the signal in the measurement channel.

4-10. Phase Sensitive Detection Circuitry. The amplified signal at this point is ready for synchronous detection. A common signal is fed to the Y inputs of integrated circuit multiplier devices U6 and U7. The 1 MHz synchronizing signals applied to the X inputs of the two multipliers are displaced in phase by 90 degrees. This results in the output of one multiplier being derived proportional to the capacitance of the DUT and the other output being related to the conductance. The primary quadrature phase relationship is accomplished by a capacitive divider network across the output of the balanced transformer T1 on A5A2. A coarse phase adjustment of the capacitance channel is provided by variable resistor R45. A fine adjustment of the phase of the

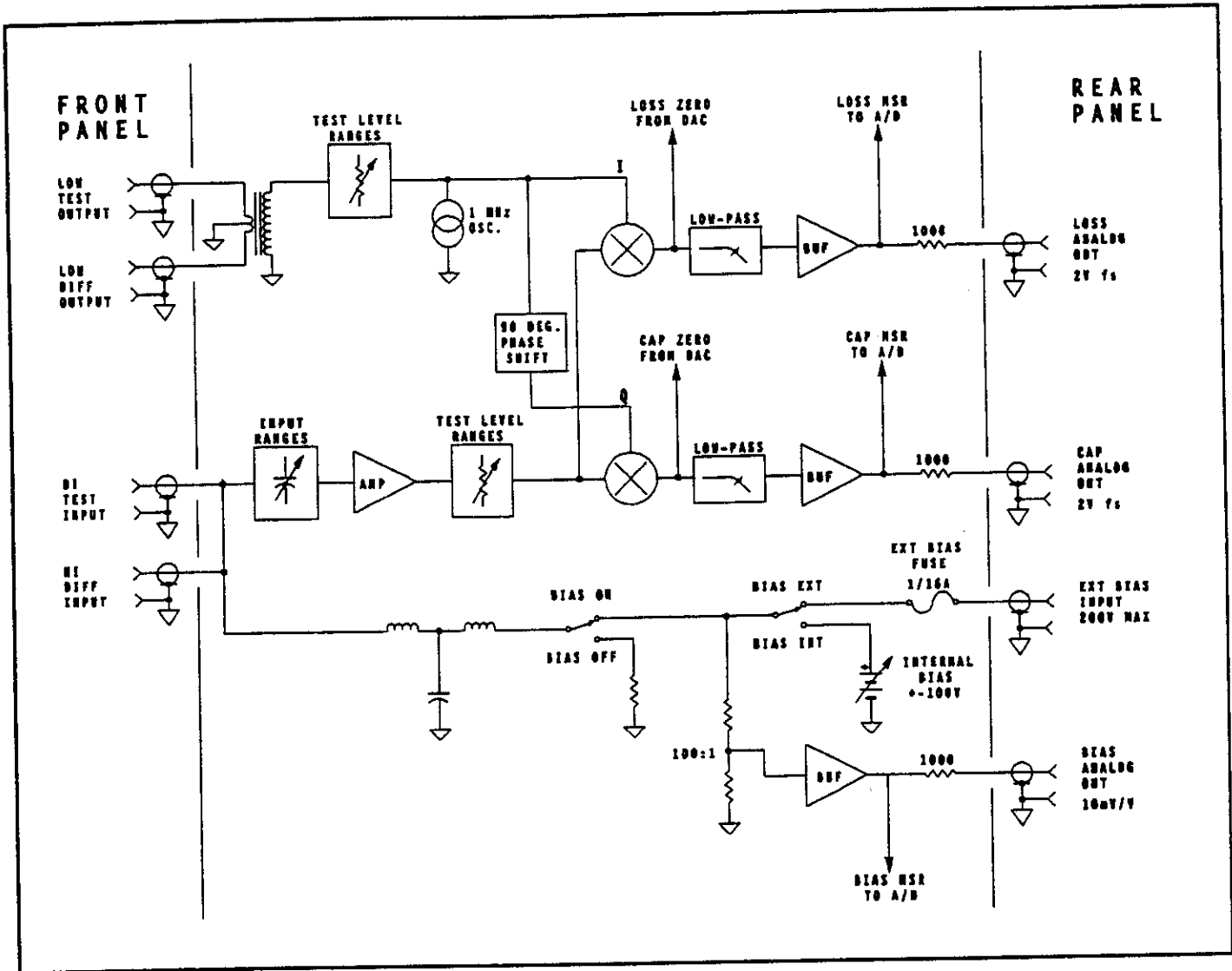

Figure 4-2. Measurement Circuits Block Diagram.

reference signal in the conductance channel is provided by a voltage from the control circuitry on A3. It is accomplished by variations of the bias on varactors CR1 and CR2.

4-11. Both measurement channels have provision for full scale adjustment by the variable resistors R30 and R33. U8 and U9 are active two pole Bessel low-pass filter circuits to suppress leak-through of the 1 MHz reference signal and harmonic components. They have a nominal cut-off frequency of 20 kHz. The analog DC outputs of these stages are sent to the internal measuring functions and to the rear panel analog output terminals.

4-12. **Measurement Zeroing Circuitry.** A zeroing operation is performed automatically upon activation of the front panel ZERO key or by executing special function 50. The DUT should not be connected to measurement terminals

during this process.

4-13. During the zeroing activity, the EEPROM ZERO storage locations are cleared of prior values and a new set of values for both capacitance and loss is obtained related to the residual readings at this time. These values are stored and applied as offset values to the detector circuits during subsequent measurements. Operation of this function with the ZERO key provides new zero values for the current test level in use on all 4 measurement ranges. Special function 50 derives new zero values on all 4 measurement ranges and at all 4 available test levels.

4-14. **D.C. Bias Circuitry.** Bias is supplied to the DUT either from an external source or the internal variable supply. The regulators for the internal high voltage variable supply are located on the mother PC board assembly, A4. The gain

of the booster amplifier, U18, for the regulators is set by the values of resistors R15 and R17. Reed relays K1 and K2 perform the INT/EXT and ON/OFF switching functions. The variable supply has an internal ranging operation whereby the full scale value is switched from ± 100 volts to ± 20 volts. The divider consisting of R21 and R22 provides a 1:1 or 5:1 scaling factor as controlled by analog switch U2 on A4. The final output bias value is controlled by an analog output signal from the bias DAC (digital-to-analog converter) on the input/output section of the control assembly, A3. R18 and R20 on the mother board provide a low level signal proportional to the bias voltage to feed buffer, U1A, which drives the sensing and monitoring circuitry.

4-15. Digital Control Circuitry. Refer to Figures 7-7, 7-8 and 7-9 in the Schematic Diagram section of this manual.

4-16. Microprocessor U29 is a dedicated IEEE-488 bus controller device which handles the external bus instructions and communicates them to the internal microprocessor, U8. U31 and U32 are transceivers passing the bus data and control signals in either direction from the bus processor to an external IEEE-488 controller.

4-17. ROM devices U10 and U11 contain the preprogrammed instruction sequences utilized in various portions of the measurement routines. The RAM devices U12 and U13 contain storage locations for function settings and data values generated during the measurement cycle. Decoder, U17, provides the chip select signals to implement a read or write instruction at an addressed memory location. The front-panel setups are also stored in the RAM devices.

4-18. EEPROM, U15 contains calibration data used in correcting measured parameters during the measurement cycle. The values are saved in locations of this device whenever a calibration against an external standard is invoked. U17 also provides decoding of the read and write instructions implemented for control of U15. U18 senses the +5 volt supply powering the RAM and EEPROM devices. A defined drop or interruption of this voltage causes an internal battery to be applied to the memory ICs preventing a loss of data.

4-19. The major signal lines for operation of the instrument are identified as ADDRESS, CONTROL, and DATA. The ADDRESS signals are utilized to tell the system where to look in memory for a particular instruction or data value. The CONTROL signals are used to synchronize the read/write operation of memories and peripherals. The DATA signals define the value of a measurement or stored correction parameter, or status condition, in coded form.

4-20. U1 generates independent read and write strobes from the microprocessor read and write signal line. These signals are required by the memory and peripheral devices. U3 is a priority encoder that translates the interrupt signals to a form

required by microprocessor, U8.

4-21. A crystal stabilized oscillator is utilized to provide the clock signals to synchronize the timing of the control and data operations. Oscillator, A3Y1, generates an 18.43 MHz TTL waveform for this purpose. This signal is applied to a divider circuit, U6, which derives the desired sub-multiple timing waveforms. The division ratios required are 2, 4, and 8. The main microprocessor, U8 on subassembly A3, and "DTAK" logic sequencer (U2) are clocked at 9.215 MHz. The bus processor, U29, operates at 4.607 MHz and the keyboard interface circuit, A2U4, operates at 2.303 MHz.

4-22. Programmable Logic Array U2, operates as a logic sequencer which controls data bus timing to and from peripheral devices.

4-23. Integrated circuit, U7, operates as a power monitor for the microprocessor +5 volt supply. In the event the power is removed, it terminates the microprocessor operation in a sequence such that the stored information is not corrupted.

4-24. The control circuit output signals for setting various operational functions and range selection are provided through integrated circuit latches U24 and U26. The output lines are latched until changed by keyboard control or bus instruction. The decoder device U19 provides the TTL code for the desired configuration. The functions controlled are the gain and attenuator settings in the amplifier chain, the capacitance range, and the bias configuration for the measuring circuitry. Note that the ADDRESS, CONTROL, and DATA lines to these circuits are buffered by U20, U21, and U22.

4-25. Analog values of the parameters derived from the measuring circuits are transmitted to the A/D converter, U28. This device converts each value to a digital format in which it may be sent to the external controller and front panel digital display. The measured parameters include capacitance, conductance, temperature, and bias level. The decoder circuit U23 supplies the timing logic for the measurements.

4-26. Preset values for test level, bias, phase trim, and zero offset for C and G are applied to the digital-to-analog converters (DACs) U25, U27, and U29. Decoder, U23, also provides the TTL logic associated with these functions. The address and data line signals determine the actual value of the parameter. The DACs read the data which is applied in digital format and convert it to a proportional analog signal.

4-27. Measurement Averaging. The averaging capability of the Model 7200 enables the user to set an optimum condition of speed or settling time for the measurement. This is accomplished by storing a number of successive readings in RAM. Arithmetic averaging is performed before a data value

Theory of Operation

is sent to the internal display or external data bus. Measuring time increases directly with the number of averaged readings. In the automatic mode (Special Function 30), a default value is selected for each test level setting. Special functions 31 through 39 allow user selection of the number of averages from 1 through 500 in 1, 2, 5 scaled increments.

4-28. Internal Temperature Measurement Circuitry.

The measuring circuits are susceptible to errors in amplitude and phase when subjected to significant changes in ambient temperature. Thermal sensor U10 on the detector assembly A5A2 causes a linear change in the resistive network output voltage proportional to temperature. The value is digitized by the A/D converter U28 on the control board assembly. Temperature can be read on the front panel display by accessing special function 55. A calculation of the error in either amplitude or phase is also accessible by activation of special functions 56 and 57 as outlined in the operation section of the manual. A new zeroing operation is recommended whenever the temperature is noted to have changed significantly from a previous zero calibration.

4-29. Front Panel Keyboard Circuitry. The keyboard assembly, A2A2, is a conventional matrix configuration. In operation, keys are scanned by a strobe signal generated by U4 on the display assembly, A2A1. Activation of any particular key is detected and an appropriate instruction code is generated by the logic circuitry. Integrated circuit U4 on the display assembly A2A1 is a programmable keyboard inter-

face device which performs all of these functions.

4-30. Front Panel Display Circuitry. The display board, A2A1, controls the front panel vacuum fluorescent display, A8. The unit is capable of displaying a row of 20 alphanumeric characters. In addition, a group of LED indicators identifies the presence of activities related to bus operations. The display decoding operations are all accomplished by circuitry internal to the display module.

4-31. Power Supply Circuitry. The instrument power supplies are located on the control board assembly, A3. Two +5 volt supplies are employed. Each utilizes a conventional three terminal regulator. (U33 and U34) One unit supplies the requirements for the primary integrated circuit logic devices. The other supplies the input/output circuits. The measuring circuits are powered by +15 volt and -15 volt supplies. The regulators for this section, U35 and U36, are nominal 5 volt regulators operating 10 volts above ground potential. U38 provides the +10 volt reference voltage. The internal bias supply, as noted in section 4-24, is located on the mother board, A4.

4-32. Rear Panel Analog Output Circuitry. Analog outputs for plotting purposes are available via BNC connectors on the rear panel. The parameters C, G, and bias voltage are scaled with 2.0 volts representing full scale. The source impedance is 1000 ohms.

SECTION V MAINTENANCE

5-1. INTRODUCTION.

5-2. This section contains maintenance information for the Model 7200 Capacitance Meter. Included are performance tests, software and physical calibration procedures, a procedure for the removal and replacement of components, cleaning information, inspection, troubleshooting information and other general information for proper maintenance.

WARNING

Although this equipment has been designed according to international safety standards, general safety precautions must be observed during all phases of operation, service and repair of this instrument. Failure to comply with the precautions listed in the Safety Summary at the front of this manual or with the specific warnings given throughout this manual could result in a serious injury or death. Service and adjustments should only be performed by qualified and safety-minded service personnel.

5-3. **Required Equipment.** The test equipment and tools required for evaluation, calibration and maintenance are listed in Table 5-1. Equipment of equivalent characteristics may be substituted for any item listed. However, the performance tests are based on the assumption that the recommended test equipment is used.

5-4. **Cleaning Procedure.** Painted surfaces can be cleaned with a commercial spray-type window cleaner or with a mild soap and water solution.

CAUTION

Avoid the use of chemical cleaning agents that might damage the plastics used in the instrument. Recommended cleaning agents are isopropyl alcohol, a solution of 1 part kelite and 20 parts of water or a solution of 1% mild detergent and 99% water.

5-5. **Removal of Covers.** To remove the instrument covers proceed as follows:

1. Disconnect all the cables and the power cord from the instrument.
2. Remove the top cover by removing the two No. 6 screws, tilt up and push toward the rear.

3. Turn the instrument over and remove the bottom cover in the same manner.

5-6. **Visual Checks.** It is a good practice to perform a visual check of the instrument for any damage caused by vibration, excessive shock, loose hardware, parts and cable connections, broken wires, dirt or overheating. Correct such problems before you perform the performance tests.

5-7. **Component Removal.** Most components are readily accessible for inspection and replacement when the instrument's covers are removed. Solid-state circuits components mounted on circuit boards are used throughout the instrument. Care must be given during removal and installation of these boards. The pins (leads from the feedthrough capacitors) must be straight before a removed board can be reinstalled. Standard printed circuit board maintenance techniques are required for the removal and replacement of parts. Excessive heat must be avoided; a low wattage soldering iron and suitable heat sink should be used for all soldering and unsoldering operations.

5-8. **Removal and Replacement of EPROMs.**

1. Remove the instrument's top cover as described in paragraph 5-5.
2. The two EPROMs are designated as U10 and U11 and are clearly recognized by the bright orange stickers. Care must be taken to ensure that each EPROM is inserted into the proper socket. The EPROMs are not interchangeable. The first three numbers of the five character code on the label designates the EPROM location. The device with the 590 code belongs in the U10 location and the device with the 591 code belongs in the U11 location.

CAUTION

When removing and replacing an integrated circuit (IC), note the mark or a notch that is used for pin number 1 identification.

3. Remove the IC with a straight pull away from the board and install the replacement.

WARNING

High voltages exist at various points in the instrument that can if contacted cause personal injury. Observe all safety precautions. Service and adjustments should

Table 5-1. Recommended Test Equipment and Tools.

INSTRUMENT	CRITICAL SPECIFICATIONS	USAGE		MODEL
		Cal	Test	
Digital Multimeter	Accuracy: 0.005% Resolution: 1 mV	✓	✓	Fluke 8840A or equal
RF Millivoltmeter	Accuracy: 1.0% Resolution: .1 mV		✓	Boonton Model 9200 or equal
Power Supply	Level Range: 0 to 200VDC		✓	HP 6209 or equal
Oscilloscope	Bandwidth: 60 MHz	✓		Tektronix 2215 or equal
Capacitance Standards	2.000 pF, nominal, ± 0.1 %	✓	✓	Model 76-2A/11(1.95pF)
	20.00 pF, nominal, ± 0.1 %	✓	✓	Model 76-2A/21(19.9pF)
	200.0 pF, nominal, ± 0.1 %	✓	✓	Model 76-2A/31(199pF)
	2000 pF, nominal, ± 0.1 %	✓	✓	Model 76-2A/41(1950pF)
Conductance Standards	2.000 μS, nominal, ± 0.1 %	✓	✓	Model 76-4A/11(1.9μS)
	20.00 μS, nominal, ± 0.1 %	✓	✓	Model 76-4A/21(19μS)
	200.00 μS, nominal, ± 0.1 %	✓	✓	Model 76-4A/31(190μS)
	2000 μS, nominal, ± 0.1 %	✓	✓	Model 76-4A/41(1900μS)
Loading Capacitors	200 pF, ± 5 %	✓	✓	See Fig 5-1
	500 pF, ± 5 %	✓	✓	See Fig 5-1
Adapters and Cables	BNC type TEE adapters, 2 required	✓	✓	
	Binding Posts to BNC Male Adapter	✓	✓	
	BNC Female to double banana plug	✓	✓	
	36" Cables with BNC male connectors, 2 required	✓	✓	

be performed by trained service personnel only.

4. Connect the power to the instrument and set the LINE ON/OFF switch to ON.

5. Depress the LCL/INIT key to initialize the instrument. The new firmware number will appear on the display

for a few seconds before the instrument resumes normal operation.

6. Set the LINE ON/OFF switch to OFF disconnect all the power to the instrument and replace the instrument's top cover.

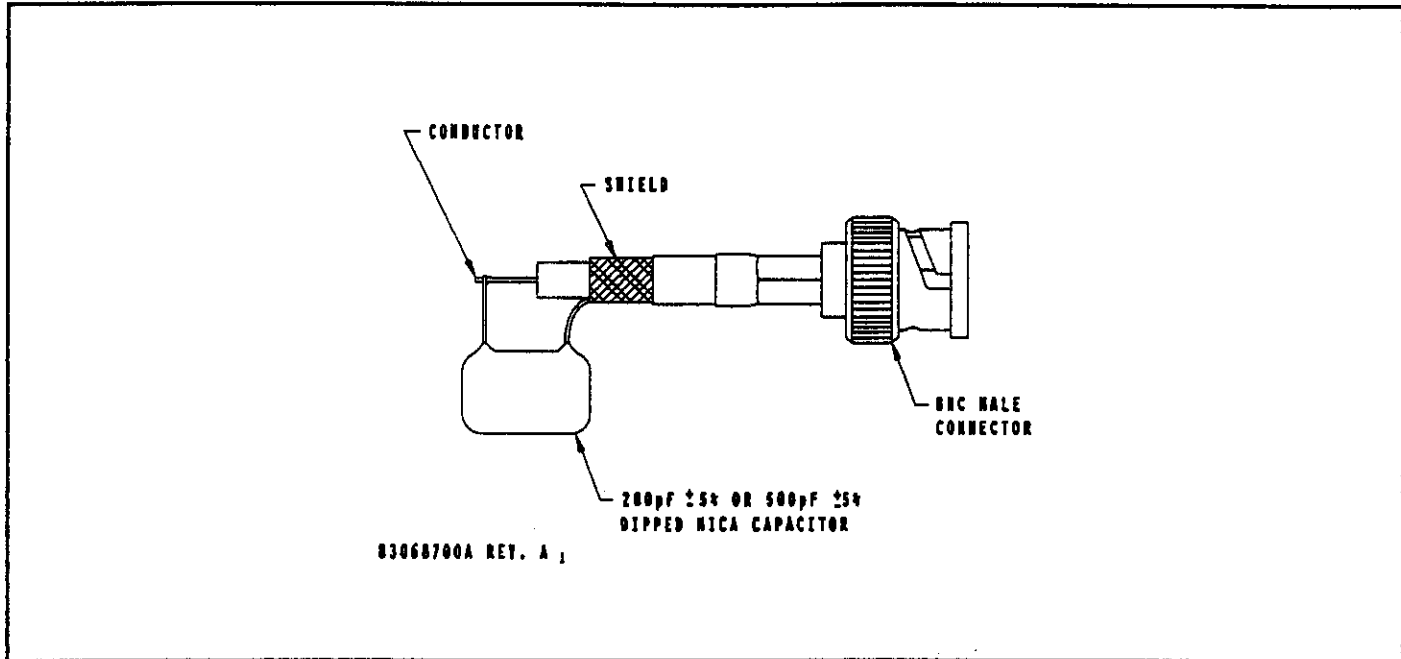

Figure 5-1. Loading Capacitor.

5-9. PERFORMANCE VERIFICATION

5-10. The performance tests should be performed about every 12 months or after the instrument has been repaired. The performance tests also should be performed when the instrument is first received. A two hour warm-up period is required before beginning the performance tests. The recommended test equipment and standards required for the performance tests are listed in Table 5-1. The following performance tests are required to ensure that the instrument is operating within specification.

1. Test level function check.
2. Capacitance (C_p) accuracy test.
3. Conductance (G) accuracy test.
4. Capacitance analog output linearity test.
5. Conductance analog output linearity test.
6. Internal bias accuracy test.
7. External bias accuracy test.
8. Input loading test. (optional)

The remaining capacitance and loss functions: C_s , Q , R_p , R_s , and D are calculated from C_p and G and, therefore, do not need to be tested.

5-11. **Temperature Influence.** The measurement technique used by the Model 7200 derives the conductance and capacitance of the test specimen by analyzing the magnitude and phase of the 1 MHz test signal that appears at the HI input connectors. The influence of temperature on the absolute accuracy of Capacitance and Loss measurements is evident as magnitude and phase errors. The magnitude of the measurement may vary by up to $\pm 0.017\% / ^\circ\text{C}$. The phase error can vary by up to $\pm 0.2^\circ$ of phase from 0° (conductance) and 90° (capacitance) for every $\pm 1^\circ\text{C}$ change in temperature. As a general rule, the major parameter is primarily influenced by the magnitude error and the phase error has the greater influence on the minor parameter.

5-12. When the full-scale capacitance ranges of the 7200 are software calibrated, the internal temperature is measured and stored in nonvolatile memory with the correction factors for the ranges. Special function 55 is provided as a means to display the internal temperature measurement. Two additional special functions, 56 and 57, are provided to display the worst-case magnitude and phase errors as a function of $\Delta^\circ\text{C}$ from the calibration temperature. These special functions measure the actual internal temperature (SPCL 55), calculate the $\Delta^\circ\text{C}$ from the temperature value stored at the moment of calibration, and multiply the $\Delta^\circ\text{C}$ by the magnitude and phase error specifications. The Option/Test switch A3S1 position 6 must be set to the open position in order to access special functions 50 through 59. Refer to paragraph 3-64.

5-13. Calculating the temperature influence on the major parameter is straightforward. For example, a displayed

Table 5-2 Phase Error Effect On Conductance (G).

Temp Error	Phase Error	2.000 pF	20.00 pF	200.0 pF	2000 pF
± 1 °C	± 0.2 °	± 0.04 μS	± 0.4 μS	± 4 μS	± 40 μS
± 2 °C	± 0.4 °	± 0.09 μS	± 0.9 μS	± 9 μS	± 90 μS
± 3 °C	± 0.6 °	± 0.13 μS	± 1.3 μS	± 13 μS	± 130 μS
± 4 °C	± 0.8 °	± 0.18 μS	± 1.8 μS	± 18 μS	± 180 μS
± 5 °C	± 1.0 °	± 0.22 μS	± 2.2 μS	± 22 μS	± 220 μS
± 6 °C	± 1.2 °	± 0.26 μS	± 2.6 μS	± 26 μS	± 260 μS
± 7 °C	± 1.4 °	± 0.31 μS	± 3.1 μS	± 31 μS	± 310 μS
± 8 °C	± 1.6 °	± 0.35 μS	± 3.5 μS	± 35 μS	± 350 μS
± 9 °C	± 1.8 °	± 0.39 μS	± 3.9 μS	± 39 μS	± 390 μS
± 10 °C	± 2.0 °	± 0.44 μS	± 4.4 μS	± 44 μS	± 440 μS
± 11 °C	± 2.2 °	± 0.48 μS	± 4.8 μS	± 48 μS	± 480 μS
± 12 °C	± 2.4 °	± 0.53 μS	± 5.3 μS	± 53 μS	± 530 μS
± 13 °C	± 2.6 °	± 0.57 μS	± 5.7 μS	± 57 μS	± 570 μS
± 14 °C	± 2.8 °	± 0.61 μS	± 6.1 μS	± 61 μS	± 610 μS
± 15 °C	± 3.0 °	± 0.66 μS	± 6.6 μS	± 66 μS	± 660 μS

capacitance of 198.5 pF with a magnitude error of ± 0.230% (SPCL 56) would be in error by as much as ± 0.457pF. The phase error effect on the minor parameter is more difficult to calculate. The formulae for calculating the phase error effect on conductance as a minor parameter is as follows:

$$G = (\text{TAN}(\text{phase error}(\pi/180)) \omega C_p)$$

The formula for calculating the phase error effect on capacitance as a minor parameter are as follows:

$$C_p = (\text{TAN}(\text{phase error}(\pi/180)) G / \omega)$$

Where:

G = conductance (μS)

phase error = value displayed by SPCL 57

$\omega = 2 \pi \times 1000000 \text{ Hz}$

Cp = parallel capacitance (μF)

Minor parameter example: a displayed parallel capacitance (Cp) of 15.25 pF with a phase error due to temperature of ± 0.20° (SPCL 57) would have a measurement error of ± 0.3 μS of conductance. Table 5-2 lists the effects of phase error on conductance as the minor parameter

over a ± 15° C temperature range. Table 5-3 lists the effects of phase error on capacitance as the minor parameter over a ± 15° C temperature range.

5-14. Instruments with software program codes 921208 and greater include two special functions, 8 and 9, which automatically calculate and display the worst-case error for capacitance and conductance. All parallel capacitance and conductance error terms listed in Table 1-1, including temperature influence, are calculated and displayed as a single error value.

5-15. Test Level Functional Check. There are four test level selections on the Model 7200: 100, 50, 30, and 15 mV. The test levels are approximate and therefore only a functional check is required. Refer to paragraph 3-45 for information about selecting the test level. To perform the test level functional test, proceed as follows.

1. Depress the LCL/INIT key to initialize the instrument.
2. Connect the TEST LO to the RF Millivoltmeter.
3. Set the test level to the values listed in Table 5-4 and record the RF level measurements in the table.
4. Compare the measured values to the error limits and

Table 5-3 Phase Error Effect On Capacitance (Cp).

Temp Error	Phase Error	2.000 μ S	20.00 μ S	200.0 μ S	2000 μ S
$\pm 1^\circ$ C	$\pm 0.2^\circ$	± 0.001 pF	± 0.01 pF	± 0.1 pF	± 1 pF
$\pm 2^\circ$ C	$\pm 0.4^\circ$	± 0.002 pF	± 0.02 pF	± 0.2 pF	± 2 pF
$\pm 3^\circ$ C	$\pm 0.6^\circ$	± 0.003 pF	± 0.03 pF	± 0.3 pF	± 3 pF
$\pm 4^\circ$ C	$\pm 0.8^\circ$	± 0.004 pF	± 0.04 pF	± 0.4 pF	± 4 pF
$\pm 5^\circ$ C	$\pm 1.0^\circ$	± 0.005 pF	± 0.05 pF	± 0.5 pF	± 5 pF
$\pm 6^\circ$ C	$\pm 1.2^\circ$	± 0.006 pF	± 0.06 pF	± 0.6 pF	± 6 pF
$\pm 7^\circ$ C	$\pm 1.4^\circ$	± 0.007 pF	± 0.07 pF	± 0.7 pF	± 7 pF
$\pm 8^\circ$ C	$\pm 1.6^\circ$	± 0.008 pF	± 0.08 pF	± 0.8 pF	± 8 pF
$\pm 9^\circ$ C	$\pm 1.8^\circ$	± 0.009 pF	± 0.09 pF	± 0.9 pF	± 9 pF
$\pm 10^\circ$ C	$\pm 2.0^\circ$	± 0.010 pF	± 0.10 pF	± 0.10 pF	± 10 pF
$\pm 11^\circ$ C	$\pm 2.2^\circ$	± 0.011 pF	± 0.11 pF	± 0.11 pF	± 11 pF
$\pm 12^\circ$ C	$\pm 2.4^\circ$	± 0.012 pF	± 0.12 pF	± 0.12 pF	± 12 pF
$\pm 13^\circ$ C	$\pm 2.6^\circ$	± 0.013 pF	± 0.13 pF	± 0.13 pF	± 13 pF
$\pm 14^\circ$ C	$\pm 2.8^\circ$	± 0.014 pF	± 0.14 pF	± 0.14 pF	± 14 pF
$\pm 15^\circ$ C	$\pm 3.0^\circ$	± 0.015 pF	± 0.15 pF	± 0.15 pF	± 15 pF

record the results, pass or fail, in the table.

5-16. Capacitance and Conductance Test Limits. The limits shown in Tables 5-5 and 5-6 were computed based on the measurement specification excluding temperature influence. The temperature influence, although small, can be computed as explained in the paragraphs 5-11 through 5-13 and the result added to the Error Limit in the tables. Furthermore, the table limits were computed based on the assumption that the capacitance and the conductance standards used are between 90% and 100% of full-scale. Instruments with program codes 921208 and greater include special functions 8 and 9 which automatically calculate and display the worst-case error limits of capacitance and conductance, including temperature influence. Since these special functions save test time, it is strongly recommended that they be used, if available, in place of the limits given in Tables 5-5 and 5-6. The following procedures will only reference the limits in the tables for simplicity.

5-17. Capacitance (Cp) Performance Test. To perform the capacitance accuracy test, proceed as follows.

1. Depress the LCL/INIT key to initialize the instrument.
2. Connect one side of the 2 pF standard to only the TEST HI connector on the Model 7200.

3. Depress the ZERO key and wait until the zeroing routine is complete.

4. Enter special function 12 to hold the 2 pF range.

5. Connect the capacitance standard to the TEST HI and LO connectors and depress the Cp key.

6. Record the values of the capacitance standard and the Cp and G readings in Table 5-5.

7. Verify that the difference between the standard and measured values is within the error limits and record the results, pass or fail, in Table 5-5.

8. Repeat steps 4 through 7 for the 20, 200, and 2000 pF capacitance standards and enter special functions 13, 14, and 15, respectively, to hold the appropriate capacitance range in step 4.

5-18. If any of the capacitance performance tests have failed, a calibration may be necessary. See paragraph 5-31.

5-19. Conductance (G) Performance Test. To perform the conductance accuracy test, proceed as follows.

1. Depress the LCL/INIT key to initialize the instrument.

Section 5

2. Connect one side of the $2\ \mu\text{S}$ standard to only the TEST HI connector on the Model 7200.
3. Depress the ZERO key and wait until the zeroing routine is complete.
4. Enter special function 12 to hold the $2\ \mu\text{S}$ range.
5. Connect the conductance standard to the TEST HI and LO connectors and depress the Cp key.
6. Record the values of the conductance standard and the G and Cp readings in Table 5-6.
7. Verify that the difference between the standard and measured values is within the error limits and record the results, pass or fail, in Table 5-6.
8. Repeat steps 4 through 7 for the 20, 200, and 2000 μS conductance standards and enter special functions 13, 14, and 15, respectively, to hold the appropriate conductance range in step 4.

5-20. If any of the conductance performance tests have failed, a calibration may be necessary. See paragraph 5-31.

5-21. **Analog Output Linearity Performance Test.** The expected ideal magnitude of the output voltage at the capacitance and conductance analog outputs is 2000 mV for 2000 counts (full-scale) on each range. Although the magnitude of the 2 volt output has an error of typically less than 1%, it is too large to be ignored for most linearity measurements. Therefore, depending on what major parameter is being measured, the actual mV/pF or mV/ μS scale factor must be normalized in order to accurately measure linearity. This ratio measurement is made near full-scale so that any linearity error has a negligible effect. In the instructions that follow, the analog output accuracy is further calculated from the scale factor and expressed as an error in percent. As an example, a capacitance standard with a value of 1951 pF is connected to the Test HI and LO inputs and the DMM measurement value is 1945 mV.

The scale factor is:

$$1945 / 1951 = 0.9969$$

The analog output accuracy is:

$$100\% \times (\text{Scale Factor} - 1) = -0.31\%$$

5-22. Two other sources of error must be removed before the linearity can be accurately measured: zero offset error and range-to-range crossover error. The zero offset error is removed by first zeroing the Model 7200 (held on the 2000 pF/ μS range) and then further compensating for the residual

offset at the analog output with the OFFSET mode on the DMM. The range-to-range crossover error is avoided by holding the 2000 pF/ μS range during a linearity measurement.

5-23. **Capacitance Analog Output Linearity Test.** To perform the capacitance analog output linearity test, proceed as follows.

1. On the Model 7200 depress LCL/INIT key to initialize the instrument.
2. Connect the DMM input to the CAP ANALOG OUTPUT on the rear panel of the Model 7200 with a BNC cable and adapter.
3. Connect only one terminal of the 2 pF standard to the TEST HI connector and zero the instrument.
4. Enter special function 15 to set and hold the 2000 pF range.
5. Set the DMM to VDC, 20 volt range, and toggle the OFFSET key to enable the offset mode.
6. Connect the 2000 pF capacitance standard to the TEST HI and LO connectors, measure the analog output voltage and calculate the scale factor using the following formula.

$$\text{Scale Factor} = \text{DMM value (mV)} / \text{Standard Value (pF)}$$
7. Record the calculated scale factor in Table 5-7.
8. Calculate the Analog Output Accuracy using the following formula and record the result in Table 5-7.

$$\text{Accuracy (\%)} = 100\% \times (\text{Scale Factor} - 1)$$
9. Disconnect the 2000 pF capacitance standard and connect the 200 pF capacitance standard.
10. Calculate the Adjusted Standard Value by using the following formula and record the result in Table 5-7.

$$\text{Adjusted Standard} = \text{Scale Factor} \times \text{Standard Value}$$
11. Record the DMM reading (mV = pF) in Table 5-7.
12. Subtract the DMM value from the Adjusted Standard Value and compare the result to the Error Limits. Record the result, pass or fail, in Table 5-7.
13. Repeat steps 9 through 12 using the 20 pF and 2 pF capacitance standards instead of the 200 pF capacitance standard.

Maintenance

5-24. Conductance Analog Output Linearity Test. To perform the conductance analog output linearity test, proceed as follows.

1. On the Model 7200 depress LCL/INTT key to initialize the instrument.
2. Connect the DMM input to the LOSS ANALOG OUTPUT on the rear panel of the Model 7200 with a BNC cable and adapter.
3. Connect only one terminal of the $2\ \mu\text{S}$ conductance standard to the TEST HI connector and zero the instrument.
4. Enter special function 15 to set and hold the $2000\ \mu\text{S}$ range.
5. Set the DMM to VDC, 20 volt range, and toggle the OFFSET key to enable the offset mode.
6. Connect the $2000\ \mu\text{S}$ conductance standard to the TEST HI and LO connectors, measure the analog output voltage and calculate the scale factor using the following formula.

$$\text{Scale Factor} = \text{DMM value (mV)} / \text{Standard Value } (\mu\text{S})$$

7. Record the calculated scale factor in Table 5-8.
 8. Calculate the Analog Output Accuracy using the following formula and record the result in Table 5-8.
- $$\text{Accuracy (\%)} = 100\% \times (\text{Scale Factor} - 1)$$
9. Disconnect the $2000\ \mu\text{S}$ conductance standard and connect the $200\ \mu\text{S}$ conductance standard.
 10. Calculate the Adjusted Standard Value by using the following formula and record the result in Table 5-8.

$$\text{Adjusted Standard} = \text{Scale Factor} \times \text{Standard Value}$$

11. Record the DMM reading ($\text{mV} = \mu\text{S}$) in Table 5-8.
12. Subtract the DMM value from the Adjusted Standard Value and compare the result to the Error Limits. Record the result, pass or fail, in Table 5-8.
13. Repeat steps 9 through 12 using the $20\ \mu\text{S}$ and $2\ \mu\text{S}$ conductance standards instead of the $200\ \mu\text{S}$ conductance standard.

5-25. Internal Bias Performance Test. The internal bias test is performed by setting the internal bias supply to various levels, measuring the d.c. output voltage with a precision DMM and comparing the readings to the internal bias set-

tings. To perform the test, proceed as follows.

CAUTION HIGH VOLTAGE

1. On the Model 7200 depress LCL/INTT key to initialize the instrument.
2. Set the DMM to VDC, 200 V range and disable the OFFSET mode. Connect the DMM input to the TEST HI connector using a BNC cable and banana plug adapter.
3. Depress the BIAS ON key to enable the bias output. The green LED above the TEST HI connector will be illuminated.
4. Set the internal bias supply to the voltages given in Table 5-9, measure the output level using the DMM and record the value in the table. As the bias supply voltage is increased greater than ± 20 , verify that the LED above the HI connector changes from green to red.
5. Compare the difference between the setting and reading to the error limits and record the result, pass or fail, in the Table 5-9.

5-26. If any of the internal bias performance tests have failed, a calibration may be necessary. See paragraph 5-31.

5-27. External Bias Performance Test. The external bias test is performed by setting an external power supply to various levels, measuring the d.c. output voltage with a precision DMM and comparing the readings with external bias readings. To perform the test, proceed as follows.

CAUTION HIGH VOLTAGE

1. On the Model 7200 depress LCL/INTT key to initialize the instrument.
2. Set the DMM to VDC, 200 V range and disable the OFFSET mode. Connect the DMM input to the TEST HI connector using a BNC cable and adapter.
3. On the Model 6209B Power Supply set the current and the voltage adjustment for a minimum output. Using a BNC adapter connect the output from the power supply to the EXT BIAS INPUT on the rear panel of the Model 7200. The negative terminal of the power supply should be connected to the shield of the BNC cable (chassis ground) and the positive terminal should be connected to the center conductor of the BNC cable.

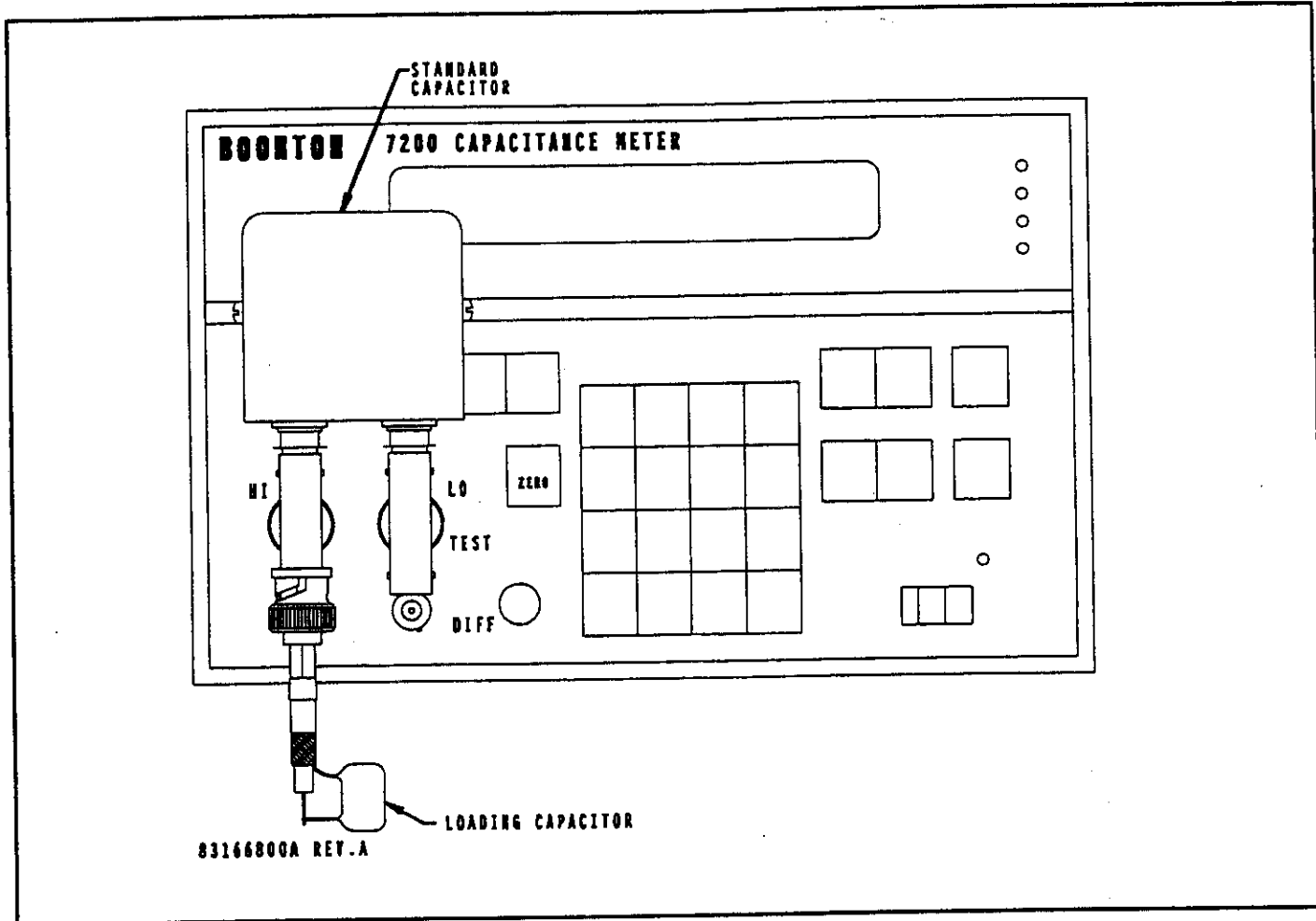

Figure 5-2. Input Loading Test Setup.

4. On the Model 7200 depress the EXT key to select the external bias measurement mode.

5. Depress the BIAS ON key to enable the bias output to the front panel HI connectors. The green LED above the TEST HI connector will be illuminated.

6. Adjust the power supply to within ± 0.5 V of the positive voltages listed in Table 5-10 and record the DMM reading and the EXT bias readings in the table. As the power supply voltage is increased greater than ± 20 , verify that the LED above the HI connector changes from green to red.

7. Compare the difference between the recorded readings to the Error Limits and record the result, pass or fail, in Table 5-10.

8. Adjust the power supply voltage for minimum output and set the Model 6209B power to off.

9. Exchange the polarity of the test leads on the power

supply (positive ground) and set the power to on.

10. Repeat steps 6 and 7 for the negative voltages listed in Table 5-10.

11. Adjust the power supply voltage for minimum output and set the Model 6209B power to off.

5-28. If any of the external bias performance tests have failed, a calibration may be necessary. See paragraph 5-31.

5-29. **Input Loading Performance Test.** The input loading test verifies that the input can be loaded with an impedance to chassis ground with minimal change in the measurement value. This effect is likely to occur when long cables are used between the instrument and the test specimen. In this test a standard capacitor is measured while a load impedance is inserted and removed between the HI input and chassis ground terminals. To perform the input loading test, proceed as follows.

1. On the Model 7200 depress the LCL/INIT key to initialize the instrument.
 2. After the instrument has initialized, connect the two BNC type TEE adapters to the TEST HI and LO connectors as depicted in Figure 5-2.
 3. Connect only one connector of the 2 pF standard capacitor to the TEST HI TEE adapter.
 4. Enter special function 12 to hold the 2 pF range.
 5. Depress the ZERO key and wait until the zeroing routine is complete.
 6. Connect the 2 pF standard capacitor to both TEE adapters connected to the TEST HI and LO connectors.
 7. Depress the Cp key and record the capacitance measurement in the Unloaded Value column in Table 5-11.
 8. Remove the standard capacitor and connect the 200 pF loading capacitor to the bottom of the connector as depicted in Figure 5-2.
 9. Depress the ZERO key and wait until the zeroing routine is complete.
 10. With the loading capacitor connected, again connect the 2 pF standard capacitor to both TEE adapters.
 11. Record the capacitance measurement in the Loaded Value column in Table 5-11.
 12. Compare the difference between the Loaded and Unloaded Values to the Error Limits and record the results, pass or fail, in Table 5-11.
 13. Disconnect the loading capacitor and connect only one connector of the 20 pF standard capacitor to the TEST HI TEE adapter.
 14. Enter special function 13 to hold the 20 pF range.
 15. Depress the ZERO key and wait until the zeroing routine is complete.
 16. Connect the 20 pF standard capacitor to both TEE adapters connected to the TEST HI and LO connectors.
 17. Depress the Cp key and record the capacitance measurement in the Unloaded Value column in Table 5-11.
 18. Remove the standard capacitor and connect the 500 pF loading capacitor to the bottom of the connector as depicted in Figure 5-2.
 19. Depress the ZERO key and wait until the zeroing routine is complete.
 20. With the loading capacitor connected, again connect the 20 pF standard capacitor to both TEE adapters.
 21. Record the capacitance measurement in the Loaded Value column in Table 5-11.
 22. Compare the difference between the Loaded and Unloaded Values to the Error Limits and record the results, pass or fail, in Table 5-11.
 23. Disconnect the loading capacitor and connect only one connector of the 200 pF standard capacitor to the TEST HI TEE adapter.
 24. Enter special function 14 to hold the 200 pF range.
 25. Depress the ZERO key and wait until the zeroing routine is complete.
 26. Connect the 200 pF standard capacitor to both TEE adapters connected to the TEST HI and LO connectors.
 27. Depress the Cp key and record the capacitance measurement in the Unloaded Value column in Table 5-11.
 28. Remove the standard capacitor and connect the 500 pF loading capacitor to the bottom of the connector as depicted in Figure 5-2.
 29. Depress the ZERO key and wait until the zeroing routine is complete.
 30. With the loading capacitor connected, again connect the 200 pF standard capacitor to both TEE adapters.
 31. Record the capacitance measurement in the Loaded Value column in Table 5-11.
 32. Compare the difference between the Loaded and Unloaded Values to the Error Limits and record the results, pass or fail, in Table 5-11.
 33. Disconnect the loading capacitor, standard capacitor and TEE adapters.
- 5-30. If any of the Performance Tests have failed, a calibration may be necessary. See paragraph 5-31. The Option/Test switch A3S1 position 6 must be set to the closed position in order to prevent access to special functions 50 through 59. Refer to paragraph 3-64.

Table 5-4. Test Level Functional Test.

Test Level Setting	Error Limits	Measured Value	Results	
			Pass	Fail
100 mV	± 10 mV	_____ mV	Pass	Fail
50 mV	± 7 mV	_____ mV	Pass	Fail
30 mV	± 6 mV	_____ mV	Pass	Fail
15 mV	± 3 mV	_____ mV	Pass	Fail

Table 5-5. Capacitance (Cp) Accuracy Test.

Nominal Standard	Standard Values	Error Limits	Measured Values	Results	
				Pass	Fail
2.000 pF	_____ pF	± 0.014 pF	_____ pF	Pass	Fail
0.000 μS	_____ μS	± 0.09 μS	_____ μS	Pass	Fail
20.00 pF	_____ pF	± 0.09 pF	_____ pF	Pass	Fail
0.00 μS	_____ μS	± 0.5 μS	_____ μS	Pass	Fail
200.0 pF	_____ pF	± 0.9 pF	_____ pF	Pass	Fail
0.0 μS	_____ μS	± 7 μS	_____ μS	Pass	Fail
2000 pF	_____ pF	± 9 pF	_____ pF	Pass	Fail
0 μS	_____ μS	± 356 μS	_____ μS	Pass	Fail

Table 5-6. Conductance (G) Accuracy Test.

Nominal Standard	Standard Values	Error Limits	Measured Values	Results	
				Pass	Fail
2.000 μS	_____ μS	± 0.14 μS	_____ μS	Pass	Fail
0.000 pF	_____ pF	± 0.009 pF	_____ pF	Pass	Fail
20.00 μS	_____ μS	± 1.0 μS	_____ μS	Pass	Fail
0.00 pF	_____ pF	± 0.045 pF	_____ pF	Pass	Fail
200.0 μS	_____ μS	± 9.1 μS	_____ μS	Pass	Fail
0.0 pF	_____ pF	± 0.41 pF	_____ pF	Pass	Fail
2000 μS	_____ μS	± 90 μS	_____ μS	Pass	Fail
0 pF	_____ pF	± 4 pF	_____ pF	Pass	Fail

Table 5-7. Capacitance Analog Output Linearity Test.

Scale Factor: _____ SF		Cap Analog Output Accuracy: _____ %		
Nominal Standard	Standard Value Adjusted By SF	Error Limits	DMM Reading (1mV/pF)	Results
200.0 pF	_____ pF	± 1.2 pF	_____ pF	Pass Fail
20.00 pF	_____ pF	± 1.02 pF	_____ pF	Pass Fail
2.000 pF	_____ pF	± 1.002 pF	_____ pF	Pass Fail

Table 5-8. Conductance Analog Output Linearity Test.

Scale Factor: _____ SF		Loss Analog Output Accuracy: _____ %		
Nominal Standard	Standard Value Adjusted By SF	Error Limits	DMM Reading (1mV/μS)	Results
200.0 μS	_____ μS	± 1.2 μS	_____ μS	Pass Fail
20.00 μS	_____ μS	± 1.02 μS	_____ μS	Pass Fail
2.000 μS	_____ μS	± 1.002 μS	_____ μS	Pass Fail

Table 5-9. Internal Bias Accuracy Test.

Internal Bias Setting	Error Limits	DMM Reading	Results
+ 100.00 V	± 0.60 V	_____ V	Pass Fail
+ 50.00 V	± 0.35 V	_____ V	Pass Fail
+ 20.000 V	± 0.11 V	_____ V	Pass Fail
+ 0.000 V	± 0.01 V	_____ V	Pass Fail
- 20.000 V	± 0.11 V	_____ V	Pass Fail
- 50.00 V	± 0.35 V	_____ V	Pass Fail
- 100.00 V	± 0.60 V	_____ V	Pass Fail

Table 5-10. External Bias Accuracy Test.

Power Supply Setting	DMM Reading	Error Limits	Ext Bias Reading	Results
+200.0 V	_____ V	± 0.9 V	_____ V	Pass Fail
+50.0 V	_____ V	± 0.5 V	_____ V	Pass Fail
+10.0 V	_____ V	± 0.4 V	_____ V	Pass Fail
+0.0 V	_____ V	± 0.4 V	_____ V	Pass Fail
-10.0 V	_____ V	± 0.4 V	_____ V	Pass Fail
-50.0 V	_____ V	± 0.5 V	_____ V	Pass Fail
-200.0 V	_____ V	± 0.9 V	_____ V	Pass Fail

Table 5-11. Input Loading Test.

Nominal Standard	Unloaded Value	Error Limits	Loaded Value	Results
2.000 pF	_____ pF	± 0.020 pF	_____ pF	Pass Fail
20.00 pF	_____ pF	± 0.20 pF	_____ pF	Pass Fail
200.0 pF	_____ pF	± 2.0 pF	_____ pF	Pass Fail

5-31. SOFTWARE CALIBRATION

5-32. If the instrument has failed the performance test or has been repaired, Software Calibration should be performed. Also, if more than 12 months have elapsed since the previous calibration, the Software Calibration is recommended. The following software calibration procedure should be performed sequentially as guided by the procedure.

5-33. To enable access to the software calibration routines, Option/Test switch A3S1 position 6 must be set to the open position. Refer to paragraph 3-64. The A5 housing cover must be in place and secured with all cover screws and the unit warmed up for at least 2 hours before attempting any calibration. To display the internal temperature, enter special function 55. For a unit that has been warmed up, with all covers in place, in a well-ventilated environment, the internal temperature indication should be approximately 20 °C above the temperature of the ambient environment.

Note

To minimize measurement errors due to temperature influence, the software calibration should be performed at an environmental temperature that is as close

as possible to the conditions where the unit will be placed in operation. If possible, perform the calibration at the same location where the unit is used and under the same operating conditions.

5-34. External Bias Calibration. This calibration procedure is designed to internally measure and remove the offset voltage in the external bias circuits. Perform the procedure as follows.

1. Depress the LCL/INIT key to initialize the instrument.
2. Depress the EXT bias key. Make certain that there is no power supply connected to the external bias input connector on the rear panel of the 7200.
3. Enter special function 51 to calibrate and remove the offset voltage. If an offset voltage is present that exceeds design parameters, Error 58 will be displayed, otherwise the EXT bias display will indicate 0.0 volts ± 1 count.

5-35. Internal Bias Calibration. This calibration procedure is designed to measure and remove the offset voltage in the internal bias supply circuits. Perform the procedure as

follows.

1. Connect the DIFF HI port to the DMM input using a BNC cable and adapter.
2. Depress the LCL/INIT key to initialize the instrument and set the INT bias voltage to 0 volts.
3. Set the DMM to the 2 volts, d.c. range.
4. Depress the BIAS ON key to enable the bias supply output.
5. Adjust the INT bias voltage using the data keypad until the DMM measurement is less than ± 1.5 mV.
6. Enter special function 52 to calibrate and remove the offset voltage. If an offset voltage is present that exceeds design parameters, Error 59 will be displayed, otherwise the INT bias display will indicate 0.000 volts.
7. Enter special function 23 to hold the 100 volt internal bias range.
8. Adjust the INT bias voltage using the data keypad until the DMM measurement is less than ± 15 mV.
9. Enter special function 52 to calibrate and remove the offset voltage. If an offset voltage is present that exceeds design parameters, Error 60 will be displayed, otherwise the INT bias display will indicate 0.00 volts.

5-36. Detector Offset Calibration. This calibration procedure is designed to internally measure and remove the offset voltage in the capacitance and conductance measurement circuits. Perform the procedure as follows.

1. Depress the LCL/INIT key to initialize the instrument.
2. Make certain that there are no cables, fixtures or components connected to the DIFF and TEST connectors on the front panel of the 7200.
3. Enter special function 50 to calibrate and remove the offset voltages in the detector circuitry. During the calibration the display will indicate the test level and measurement range. The calibration is similar to performing a ZERO operation at all four test levels.

5-37. Capacitance Full-Scale Calibration. To perform the capacitance full-scale range calibration, proceed as follows.

1. Depress the LCL/INIT key to initialize the instrument.

2. Enter special function 2 to enable the capacitance standard entry mode. The display should contain:

"C Standard 0.000 pF"

3. Enter the capacitance value marked on the 2 pF capacitance standard.

4. Enter special function 3 to enable the conductance standard entry mode. The display should contain:

"G Standard 0.000 uS"

5. Enter the conductance value marked on the 2 pF capacitance standard.

6. Enter special function 12 to hold the 2 pF range.

7. Connect the 2 pF standard to the TEST HI and LO connectors.

8. Enter special function 53 to initiate the full-scale Capacitance calibration routine. While the calibration is in process the display will contain a sequence of messages that indicate the test level followed by the value of the capacitance standard. For example:

"15 mV Cal 2.000 pF"

"30 mV Cal 2.000 pF"

"50 mV Cal 2.000 pF"

"100 mV Cal 2.000 pF"

If for any reason the unit is unable to calibrate full-scale capacitance, one or more error codes, 50 through 53, will be displayed in place of the capacitance value.

9. Enter special function 54 to initiate the conductance phase detector calibration routine. While the calibration is in process the display will contain a sequence of messages that indicate the test level followed by the conductance value of the capacitance standard. For example:

"15 mV Cal 0.000 uS"

"30 mV Cal 0.000 uS"

"50 mV Cal 0.000 uS"

"100 mV Cal 0.000 uS"

If for any reason the unit is unable to calibrate the conductance phase detector, one or more error codes, 54 through 57, will be displayed in place of the conductance value.

10. Repeat steps 1 through 9 replacing the 2 pF standard with the 20, 200, and 2000 pF capacitance standards and enter the respective special function 13, 14, and 15 in step 6 to hold the proper capacitance range.

5-38. After the calibration procedure is complete, the performance test beginning in paragraph 5-9 should be completed to verify the accuracy of the unit. If the calibration was unsuccessful, perform the adjustments procedure beginning with paragraph 5-39.

5-39. ADJUSTMENTS

5-40. The Model 7200 adjustments are listed in Table 5-6. As a general rule, it is not necessary to perform the adjustment procedure on an annual basis. The adjustments should only be performed when the unit has been repaired or if the software calibration procedure fails to calibrate the instrument. The required test equipment is listed in Table 5-1.

5-41. Before performing any adjustments, the software calibration memory must first be initialized using special function 59. Initializing the calibration memory sets the software calibration values to nominal. All adjustments should be made sequentially as guided by the procedure. After performing the adjustments, the Software Calibration procedure must be performed to complete the calibration of the instrument. Refer to paragraph 5-31.

5-42. **Calibration Memory Initialization.** On the Control Assembly set Option/Test Switch S1 position 6 to closed position to enable special functions 50 - 59. The Option/Test switch settings are shown in Table 3-5. To prepare the instrument for adjustment, proceed as follows.

1. Depress the LCL/INIT key to initialize the instrument.
2. Make certain that there are no cables, fixtures or components connected to the DIFF and TEST connectors on

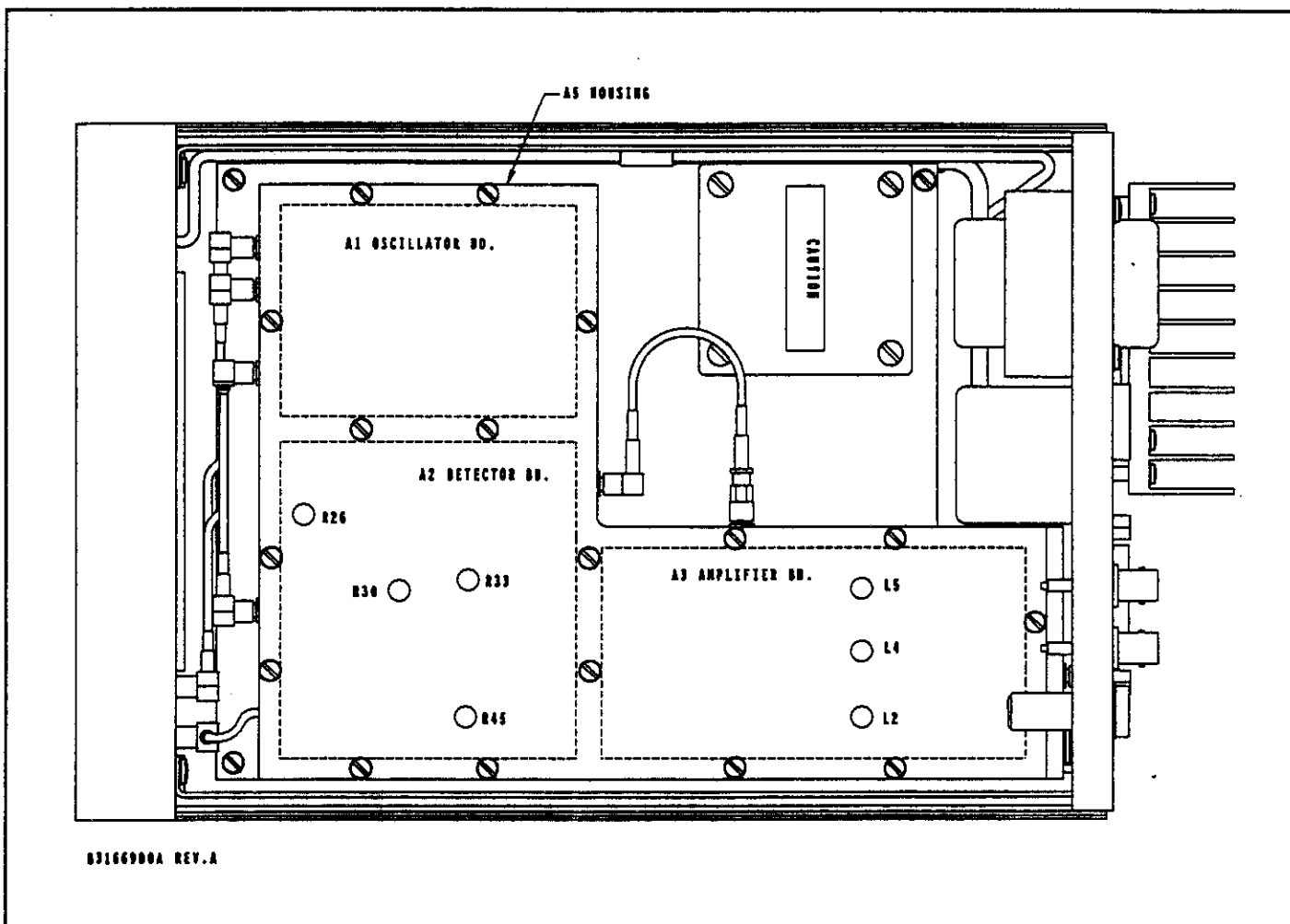

Figure 5-3. Adjustment Location Diagram.

Table 5-12. List and Location of Adjustments.

AJUSTMENTS		LOCATION
L2	2 pF Range Loading Adjustment	Amplifier Board, A5A3
L4	20 pF Range Loading Adjustment	Amplifier Board, A5A3
L5	200 pF Range Loading Adjustment	Amplifier Board, A5A3
R26	Nominal Phase Adjustment	Phase Detector Board, A5A2
R30	Conductance Full-Scale Adjustment	Phase Detector Board, A5A2
R33	Capacitance Full-Scale Adjustment	Phase Detector Board, A5A2
R45	Minor Phase Adjustment	Phase Detector Board, A5A2

the front panel of the 7200.

3. Enter special function 50 to calibrate and remove the offset voltages in the detector circuitry. During the calibration the display will indicate the test level and measurement range. The calibration is similar to performing a ZERO operation at all four test levels.

5-43. Remove the outside bottom cover to access the adjustments. Figure 5-3 shows the locations of the adjustments through the cover of the A5 assembly. Be certain that the cover on the A5 assembly is in place and secured with all screws before any adjustment is performed. The recommended warm-up time is two hours.

5-44. Amplifier Board Adjustments. Adjustments A5A3L2, A5A3L4 and A5A3L5 are factory adjustments and are expected to remain set for the life of the instrument. These adjustments should only be made when the instrument fails the input loading performance test in paragraph 5-29. Special Loading Capacitors are shown in Figure 5-1.

5-45. 2 pF Range Loading Adjustment, A5A3L2. Perform the adjustment as follows.

1. Depress the LCL/INIT key to initialize the instrument.
2. After the instrument has initialized, connect the two BNC type TEE adapters to the TEST HI and LO connectors as depicted in Figure 5-2.
3. Connect only one connector of the 2 pF standard capacitor to the TEST HI TEE adapter.
4. Enter special function 12 to hold the 2 pF range.
5. Depress the ZERO key and wait until the zeroing routine is complete.

6. Connect the 2 pF standard capacitor to both TEE adapters connected to the TEST HI and LO connectors.

7. Depress the Cp key and note the capacitance measurement.

8. Remove the standard capacitor and connect the 200 pF loading capacitor to the bottom of the connector as depicted in Figure 5-2.

9. Depress the ZERO key and wait until the zeroing routine is complete.

10. With the loading capacitor connected, again connect the 2 pF standard capacitor to both TEE adapters.

11. Adjust A5A3L2 until the indication is within ± 0.005 pF of the reading in step 7.

12. Remove the 200 pF loading capacitor and the 2 pF standard capacitor and repeat steps 5 through 11 until no adjustment is required. There may be some interaction between the zero operation and the loading adjustment.

5-46. 20 pF Range Loading Adjustment, A5A3L4. Perform the adjustment as follows.

1. Depress the LCL/INIT key to initialize the instrument.
2. After the instrument has initialized, connect the two BNC type TEE adapters to the TEST HI and LO connectors as depicted in Figure 5-2.
3. Connect only one connector of the 20 pF standard capacitor to the TEST HI TEE adapter.
4. Enter special function 13 to hold the 20 pF range.

5. Depress the ZERO key and wait until the zeroing routine is complete.
 6. Connect the 20 pF standard capacitor to both TEE adapters connected to the TEST HI and LO connectors.
 7. Depress the Cp key and note the capacitance measurement.
 8. Remove the standard capacitor and connect the 500 pF loading capacitor to the bottom of the connector as depicted in Figure 5-2.
 9. Depress the ZERO key and wait until the zeroing routine is complete.
 10. With the loading capacitor connected, again connect the 20 pF standard capacitor to both TEE adapters.
 11. Adjust A5A3L4 until the indication is within ± 0.02 pF of the reading in step 7.
 12. Remove the 500 pF loading capacitor and the 20 pF standard capacitor and repeat steps 5 through 11 until no adjustment is required. There may be some interaction between the zero operation and the loading adjustment.
- 5-47. 200 pF Range Loading Adjustment, A5A3L5.** Perform the adjustment as follows.
1. Depress the LCL/INIT key to initialize the instrument.
 2. After the instrument has initialized, connect the two BNC type TEE adapters to the TEST HI and LO connectors as depicted in Figure 5-2.
 3. Connect only one connector of the 200 pF standard capacitor to the TEST HI TEE adapter.
 4. Enter special function 14 to hold the 200 pF range.
 5. Depress the ZERO key and wait until the zeroing routine is complete.
 6. Connect the 200 pF standard capacitor to both TEE adapters connected to the TEST HI and LO connectors.
 7. Depress the Cp key and note the capacitance measurement.
 8. Remove the standard capacitor and connect the 500 pF loading capacitor to the bottom of the connector as depicted in Figure 5-2.
 9. Depress the ZERO key and wait until the zeroing

routine is complete.

10. With the loading capacitor connected, again connect the 200 pF standard capacitor to both TEE adapters.
11. Adjust A5A3L5 until the indication is within ± 0.2 pF of the reading in step 7.
12. Remove the 500 pF loading capacitor and the 200 pF standard capacitor and repeat steps 5 through 11 until no adjustment is required. There may be some interaction between the zero operation and the loading adjustment.

5-48. Phase Detector Board Adjustments. The Phase Detector Board has four adjustments: A5A2R26, R30, R33 and R45. These adjustments are used to calibrate the magnitude (full-scale) and phase of the capacitance and conductance detectors.

5-49. Nominal Phase Adjustment, A5A2R26. Perform the procedure as follows.

1. Connect the LOSS analog output on the rear panel of the 7200 to the oscilloscope input using a BNC cable.
2. Set the Oscilloscope for a vertical sensitivity of 1 volt/div, d.c. coupling and a timebase of 1 ms/div.
3. Set bit switch A3S1 position 2 to the OPEN position to enable the phase detector adjustment mode.
4. Depress the LCL/INIT key to activate the adjustment mode. The display will contain "Nominal Phase Adjustment".
5. Adjust the Oscilloscope's vertical position control until the trace is centered.
6. Connect a 200 pF capacitance standard to the TEST HI and LO connectors. A square wave should appear in the oscilloscope display.
7. Adjust A5A2R26 for equal amplitude deflection above and below the center of the oscilloscope display.
8. Set bit switch A3S1 position 2 to the closed position to disable the phase detector adjustment mode.

5-50. Capacitance Full-scale Adjustment, A5A2R33. Perform the adjustment as follows.

1. Connect the CAP analog output on the rear panel of the 7200 to the DMM input using a BNC cable and adapter.
2. Set the DMM to the 20 volts, d.c. range.

Maintenance

3. Depress the LCL/INIT key to initialize the instrument.
4. Enter special function 14 to hold the 200 pF range and depress the Cp key to display the capacitance measurement.
5. Depress the ZERO key and wait until the zeroing routine has completed.
6. Connect a 200 pF capacitance standard to the TEST HI and LO connectors.
7. Adjust A5A2R33 until the DMM measurement is within ± 1 mV of a voltage equal to the capacitance standard value in pF divided by 100. For example a 199.5 pF standard should produce between 1.994 and 1.996 volts at the CAP analog output.
8. Remove the 200 pF capacitance standard and observe the capacitance (Cp) measurement.
9. If the 7200 capacitance (Cp) measurement is greater than ± 0.1 pF, repeat steps 5 through 8. There may be some interaction between the zero value and the full-scale adjustment.

5-51. Minor Phase Adjustment, A5A2R45. Perform the adjustment as follows.

1. Depress the LCL/INIT key to initialize the instrument.
2. Enter special function 14 to hold the 200 μ S range and depress the Cp key to display the capacitance measurement.
3. Depress the ZERO key and wait until the zeroing routine has completed.
4. Connect a 200 μ S conductance standard to the TEST HI and LO connectors.
5. Adjust A5A2R46 until the capacitance (Cp) measurement is within ± 0.1 pF of the capacitance value of the 200 μ S conductance standard.
6. Remove the 200 μ S conductance standard and observe the capacitance (Cp) measurement.
7. If the capacitance (Cp) measurement is greater than ± 0.1 pF with the standard disconnected, repeat steps 3 through 6. There may be some interaction between the zero value and the minor phase adjustment.

5-52. Conductance Full-scale Adjustment, A5A2R30. Perform the adjustment as follows.

1. Connect the LOSS analog output on the rear panel of the 7200 to the DMM input using a BNC cable and adapter.
2. Set the DMM to the 20 volts, d.c. range.
3. Depress the LCL/INIT key to initialize the instrument.
4. Enter special function 14 to hold the 200 μ S range and depress the Cp key to display the capacitance measurement.
5. Depress the ZERO key and wait until the zeroing routine has completed.
6. Connect a 200 μ S conductance standard to the TEST HI and LO connectors.
7. Adjust A5A2R30 until the DMM measurement is within ± 1 mV of a voltage equal to the conductance standard value in μ S divided by 100. For example a 199.0 μ S standard should produce between 1.991 and 1.989 volts at the LOSS analog output.
8. Remove the 200 μ S conductance standard and observe the conductance (G) measurement.
9. If the 7200 conductance (G) measurement is greater than ± 1 μ S, repeat steps 5 through 8. There may be some interaction between the zero value and the full-scale adjustment.

5-53. To complete the calibration of the instrument perform the Software Calibration beginning with paragraph 5-31.

5-54. TROUBLESHOOTING

5-55. Instrument malfunction will generally be evident from the front panel indications or the IEEE-488 bus responses. The problem will fall into two general categories: catastrophic or selective failure of one subsystem.

5-56. Catastrophic failures would generally cause the Model 7200 to be completely inoperative. For instance, if the microprocessor was not operating properly the display may contain meaningless symbols and the keyboard may be unresponsive. Such failures are usually located in the power supply circuits interconnecting cables and the CPU circuitry.

5-57. Selective failures and performance out of specification are usually limited to one section of the instrument and will be evident from the performance tests or manipulation of the front panel controls. For example, incorrect or erratic

Section 5

capacitance or loss measurements will indicate worn or corroded connectors particularly at the input connectors. Further isolation of a specific problem requires an understanding of the simplified block diagrams detailed in the theory of operation section of this manual and experience troubleshooting analog and digital circuits.

5-58. Trouble Localization. The circuits in the Model 7200 are divided into three sections.

1. The microprocessor control section that contains the CPU, RAM, ROM and support logic.

2. The analog section that contains the 1 MHz oscillator, measurement ranges, amplifier, phase detectors and bias supply.

3. The interface section that consists of the power supply, keyboard, display, IEEE-488 and analog I/O interface to the analog section.

5-59. Self Diagnostic Routines. Four self-diagnostic routines have been included in the instrument to aid the troubleshooter. The Option/Test Switch Selections for these tests are shown in Table 3-5.

5-60. Lamp Test. In the lamp test all front panel LEDs and vacuum florescent display indicators are illuminated. To activate this test set bit switch A3S1 position 1 to OPEN and depress the LCL/INIT key.

5-61. Keyboard Test. In the keyboard test a numerical code is displayed when each key is pressed. Table 5-13 lists the code for each key. To activate this test set bit switch A3S1 position 3 to OPEN and depress the LCL/INIT key.

5-62. DAC Test. In the DAC test all D/A converters, A3U25, A3U27 and A3U35, on the Control PWA generate repetitive ramp outputs. The output of each converter can be measured using an oscilloscope. To activate this test set bit switch A3S1 position 1 and 3 to OPEN and depress the LCL/INIT key.

5-63. Detector Linearity Test. This test is designed to test the linearity of the zeroing D/A converters, phase detectors and A/D converter. The zeroing D/A converters are alternately set to positive and negative full-scale values while the A/D converter measures the results. A malfunction will be

Table 5-13. Key Codes.

KEY	CODE
LCL	00
G	01
7	03
8	04
9	05
V/ μ S	06
SPCL	07
BIAS ON	08
Q	09
4	11
5	12
6	13
mV/pF	14
Cp	15
INT	16
PRGM	17
1	19
2	20
3	21
CLR	22
Cs	23
EXT	24
ZERO	25
0	27
-	28
.	29
ENTER	30
SHIFT	31

indicated by a large difference between the absolute value (ignore the polarity) of the displayed numbers. Differences of 10 counts or less are typical of a properly functioning instrument. To activate this test set bit switch A3S1 position 1 and 2 to OPEN and depress the LCL/INIT key.

SECTION VI PARTS LIST

6-1. INTRODUCTION.

6-2. The replaceable parts for the Model 7200 are listed in Table 6-2. The replaceable parts list contains the reference

symbol, description, manufacturer, and both the BEC and manufacturer part numbers. Table 6-1 lists the manufacturer's federal supply code numbers.

Table 6-1. Manufacturer's Federal Supply Codes.

00213	Nutronics	32293	Intersil, Inc.
00779	Amp	32575	AMP
01121	Allen Bradley	32997	Bourns
01295	Texas Instruments	33297	NEC
02735	RCA Solid State Division	33883	RMC
03888	Pyrofilm (KDI)	51406	Murata Corporation of America
04222	AVX Ceramics Company	51640	Analog Devices, Inc.
04713	Motorola Semiconductor	54420	Dage - MTI
04901	Boonton Electronics Corporation	54426	Buss Fuses
05245	Gorcom	54473	Panasonic
06383	Panduit Corporation	56289	Sprague Electric Company
06665	Precision Monolithics	57582	Kahgan Electronics Corporation
06776	Robinson Nugent, Inc.	59474	Jeffers
07263	Fairchild Semiconductor	59660	Tusonix
11961	Semicon	61529	Aroma
13919	Burr Brown	61637	Kemet - Union Carbide
14655	Cornell-Dubilier	61935	Shurter
14752	Electro Cube, Inc.	64155	Linear Technology Corp
15542	Mini Circuits	64537	Pyrofilm (KDI)
15636	Elec-Trol	71450	CTS Corporation
17117	EMC	73138	Beckman Instruments
17856	Siliconix, Inc.	74970	E. F. Johnson
18324	Signetics Corporation	75915	Littlefuse
18542	Coto-Wabash Relay	81073	Grayhill
19505	Applied Eng'r. Products	81654	Monitor Products
19701	Mepco Electra	82389	Switchcraft
20307	Arco - Micronics	91637	Dale Electronics
24226	Gowanda Electronics	94322	Tel Labs Inc
24355	Analog Devices	95348	Gordos Corporation
27014	National Semiconductor	98291	Sealectro Corporation
27264	Molex, Inc.	S4217	United Chemicon, Inc.
28480	Hewlett-Packard Corporation	DIGIK	Digi-Key
31091	Optimax	HITAC	Hitachi
31313	Components Corporation	NDK	NDK
31918	ITT Schadow, Inc.	TOSHI	Toshiba

REF INFO	DESCRIPTION	FED	MFGPART	COMPONENT PART NO.	
07230100B MODEL: 7200	REV: BD FRAME ASSY 7200				
REFERENCE DESIGNATOR	DESCRIPTION	FED. CODE	MANUFACTURER PART NUMBER	BEC PART NUMBER	
A4A1	PWA '7600' H.V. POWER SUPPLY	04901	07643200A	07643200A	
A2	FRONT PANEL ASSY 7200			07236000A	
A3	PWA '7200' CONTROL			07231000C	
A4	PWA '7200' MOTHER			07231300B	
A6	'7200' REAR PANEL ASSY			07230200C	
W1	CABLE ASSY COAX (YEL) 6.375L			57224802A	
W3	CABLE ASSY COAX (BRN) 6.375L			57224804A	
W6	CABLE ASSY COAX RG316/U 4.00L			57228700A	
W7	CABLE ASSY COAX (GRY) 13.75L			57224803A	
W10	CABLE ASSY COAX RG316/U 4.00L			57228600A	
W13	CABLE ASSY FLAT 34 CKT 3.00L			92017900A	

REFERENCE DESIGNATOR	DESCRIPTION	FED. CODE	MANUFACTURER PART NUMBER	BEC PART NUMBER	
07230200C MODEL: 7200	REV: AD '7200' REAR PANEL ASSY				
C1	CAP PE 0.1 uF 20% 250VDC		ECQ-U2A104M	23420100A	
F1	FUSE 3/8A (0.375A) 250V SLO-BL			545532000	
F2	FUSE 1/16A (0.0625A) 250V S-B	54426	MDL 1/16	545518000	
FL1	FILTER LINE	06245	3EF1	439004000	
J15-18	CONN F COAX BNC	54420	UG-625B/U	479123000	
P1	CONNECTOR 5 CIRCUIT	06383	CE156F24-5-C	479394000	
T1	TRANSFORMER POWER			44610000A	
W15	CABLE ASSY WIRE 24GA 6C 5.00L			57127100A	
W16	CABLE ASSY WIRE 24GA 4C 5.75L			57127200A	
XF1B-2B	FUSE CARRIER GRAY 1/4 x 1-1/4	SCHUR	FEK031.1666	482114000	

REFERENCE DESIGNATOR	DESCRIPTION	FED. CODE	MANUFACTURER PART NUMBER	BEC PART NUMBER	
07230300B MODEL: 7200	REV: AA '7200' POWER SWITCH ASSY				
S1	SWITCH ROCKER DPDT (GRAY)		7201-J1-Z-Q-E-9	46532200A	

REFERENCE DESIGNATOR	DESCRIPTION	FED. CODE	MANUFACTURER PART NUMBER	BEC PART NUMBER	
07230600A MODEL: 7200	REV: F* PWA '7200' KEYBOARD				
DS1	LED GRN/ORN DIFF	54473	LN11WP38	53604400A	
DS2-5	LED RED DIFF 5082-4684	28480	HLMP-1301	536024000	
DS6	LED YELLOW DIFF 5082-4684	28480	HLMP-1401	536034000	
J2	CONNECTOR 22 CONTACT	27264	22-02-2225	479428000	
R1	RES MF 332 OHM 1% 1/4W	19701	5043ED332R0F	341260000	
S1-2,7-23	SWITCH PUSH BUTTON W/O LED	31918	200330	465294000	
S3-6,24-28	SWITCH PUSH BUTTON W/LED	31918	200480	465293000	

072308008 REV: DE PWA '7200' AMPLIFIER
MODEL: 7200

REFERENCE DESIGNATOR	DESCRIPTION	FED. CODE	MANUFACTURER PART NUMBER	BEC PART NUMBER
C1,17-19,	CAP CER 0.001uF 500V TOL	33883	BG Z5U GMV	224114000
C2	CAP MICA 100pF 5% 500V	14655	CM05FD101J03	200001000
C3,5	CAP MICA 5.0pF +-1.0pF 500V	14655	CD10CD050D03	200043000
C4,14-16,	CAP CER 1.0uF 20% 50V	04222	SR305E105MAA	224264000
C6	CAP MICA 680pF 1% 300V	14655	CD15FC681F03	200015000
C7,9	CAP MICA 82pF 1% 500V	14655	CD15ED820F	200107000
C8	CAP MICA 1000pF 1% 500V			20053300A
C10	CAP MICA 56pF 5% 300V	14655	CD5EC560J	205031000
C13	CAP MICA 0.01uF 1% 500V	14655	CD30FD103F03	203017000
C20-31	CAP CER 1.0uF 20% 50V	04222	SR305E105MAA	224264000
CR1-7,	DIODE SIG 1N914	01295	1N914	530058000
CR8-13	DIODE SIG FDH-300	27014	FDH300	530052000
CR14-15	DIODE HSCH1001 (1N6263)	28480	HSCH-1001	530174000
J1-11	SOCKET SPRING COMP LEAD .072	32575	1-332070-7	479333000
K1-3	RELAY REED 15V PSEUDO FORM "C"	18542	1632-3-1	47104800A
L1,6-10	INDUCTOR 2.2mH	00213	WEE2200	400141000
L2	INDUCTOR VAR 28-60uH	96804	9054	400377000
L3	INDUCTOR 220uH 5%	159474	1315-20J	400319000
L4	INDUCTOR VAR 14-28uH	96804	9053	400231000
L5	INDUCTOR VAR 1.5-3uH	96804	9050	400232000
Q1,3	TRANS NPN 2N3904	04713	2N3904	528071000
Q2,4	TRANS PNP 2N3906	04713	2N3906	528076000
Q5	TRANS FET 2N4221A N-CHAN	27014	2N4221A	528063000
R1-4	RES MF 10.0K 1% 1/4W	19701	5043ED10K00F	341400000
R5	RES MF 4.99K 1% 1/4W	19701	5043ED4K990F	341367000
R6,10,19,	RES MF 2.49K 1% 1/4W	19701	5043ED2K490F	341338000
R7	RES MF 100 OHM 1% 1/4W	19701	5043ED100R0F	341200000
R8	RES MF 100K 1% 1/4W	19701	5043ED100K0F	341500000
R9,18	RES MF 499 OHM 1% 1/4W	19701	5043ED499R0F	341267000
R11,16,20	RES MF 100 OHM 0.1% 1/8W	64537	PME55-T9	324118000
R12	RES MF 3.01K 1% 1/4W	19701	5043ED3K010F	341346000
R13,22	RES MF 1.000K 0.1% 1/8W	64537	PME55-T9	324241000
R14	RES MF 683.8 OHM 0.1% 1/8W	91637	CMF-55-683R8-B-T9	32422300A
R15	RES MF 216.2 OHM 0.1% 1/8W	91637	CMF-55-216R2-B-T9	32416400A
R17	RES MF 215 OHM 1% 1/4W	19701	5043ED215R0F	341232000
R21	RES MF 2.49K 1% 1/4W	19701	5043ED2K490F	341338000
R23	RES MF 499K 1% 1/4W	19701	5043ED499K0F	341567000
U1	IC 419 ANALOG SWITCH	17856	DG-419-DJ	53452400A
XU1	SOCKET IC 8 PIN	06776	ICN-083-S3-G	473041000

07230900A REV: DD PWA '7200' OSCILLATOR
MODEL: 7200

REFERENCE DESIGNATOR	DESCRIPTION	FED. CODE	MANUFACTURER PART NUMBER	BEC PART NUMBER
C1,5,10,	CAP CER 0.1uF 20% 50V	04222	SR215E104MAA	224268000
C2	CAP CER 1.0uF 20% 50V	04222	SR305E105MAA	224264000
C3	CAP MICA 240pf 5% 500V	14655	CD15FD241J	200506000
C4	CAP MICA 390pf 5% 500V	57582	KD15391J501	200108000
C6,9	CAP MICA 2700pf 5% 500V	14655	CD19-272J	200617000
C7-8	CAP MICA 3900pf 5% 500V	14655	CD19FD392J	200523000
C12-13	CAP CER 0.1uF 20% 50V	04222	SR215E104MAA	224268000
C14	CAP MICA 10pf 5% 300V	14655	CD5CC100J	205002000
C15	CAP MICA 20pf 5% 300V	14655	CD5CC200J	205017000
CR1-2,5-6	DIODE SIG 1N914	01295	1N914	530058000
CR3-4	DIODE HSCH1001 (1N6263)	28480	HSCH-1001	530174000
J1-8	SOCKET SPRING COMP LEAD .072	32575	1-332070-7	479333000
K1-2	RELAY DUAL FORM "C" 12V	AROMA	1QZE-12V	47106100A
L1	INDUCTOR 470uH 5%	00213	WEE-470	400116000
L2	INDUCTOR 100uH 5%	59474	1315-12J	400295000
L3-5	INDUCTOR 15uH 10%	00213	WEE-15	400175000
Q1	TRANS NPN MPS-U05	04713	MPS-U05	528081000
Q2	TRANS NPN 2N3866	04713	2N3866	528116000
Q3	TRANS NPN 2N3904	04713	2N3904	528071000
R1	RES COMP 5.6 OHM 5% 1/4W	01121	CB56G5	343072000
R2	RES MF 1.00K 1% 1/4W	19701	5043ED1K000F	341300000
R3-4	RES MF 1.00M 1% 1/4W	19701	5043ED1M000F	341600000
R5	RES MF 200K 1% 1/4W	19701	5043ED200K0F	341529000
R6-7	RES MF 10.0K 1% 1/4W	19701	5043ED10K00F	341400000
R8	RES MF 50.00 OHM 0.1% 1/4W	64537	PME55-T9	325916000
R12,14	RES MF 150.5 OHM 0.1% 1/8W	64537	PME55-T9	32593800A
R13	RES MF 37.35 OHM 0.1% 1/8W	64537	PME55-T9	32593500A
R17	RES MF 32.4K 1% 1/4W	19701	5043ED32K40F	341449000
R18,20	RES MF 96.25 OHM 0.1% 1/8W	64537	PME55-T9	32593700A
R19	RES MF 71.15 OHM 0.1% 1/8W	64537	PME55-T9	32593600A
T1	XFORMER RF (TT1-6-X65)	15542	TT1-6 STYLE X65	41009401A
U1	IC 78L05 VOLT REG	07263	UA78L05AWC	535044000
U2	(G) IC 356B OP AMP SELECTED	04901	535062000	535062000
XU2	SOCKET IC 8 PIN	06776	ICN-083-S3-G	473041000
Y1	CRYSTAL OSC 1.000 MHz			54790505A

07231000C REV: AH PWA '7200' CONTROL
MODEL: 7200

REFERENCE DESIGNATOR	DESCRIPTION	FED. CODE	MANUFACTURER PART NUMBER	BEC PART NUMBER
BT2	CELL LITHIUM 3V	54473	BR2325-1HB	556007000
C1,3-4,	CAP CER 0.1uF 20% 50V	04222	SR215E104MAA	224268000
C2,10	CAP TANT 4.7uF 10% 10V	56289	196D475X9010HA1	283226000
C5-6,33-34	CAP EL 100uF 20% 25V	54217	SM-25-VB-101M	283334000
C7	CAP CER 3900pf 10% 100V	61637	C052K392K1X5CA	224319000
C8	CAP MICA 560pf 1% 300V	14655	CD15FC561F	200091000
C9	CAP MICA 2200pf 5% 500V	57582	KD19222J501	200525000

07231000C REV: AH PWA '7200' CONTROL (CONT.)
MODEL: 7200

REFERENCE DESIGNATOR	DESCRIPTION	FED. CODE	MANUFACTURER PART NUMBER	BEC PART NUMBER
C11-32,	CAP CER 0.1uF 20% 50V	04222	SR215E104MAA	224268000
C35-36	CAP CER 0.01uF 20% 500V	33883	BGP Z5U W/FDCL	224271000
C37-39,56,	CAP TANT 1.0uF 10% 35V	56289	199D105X9035AA2	283216000
C40-43,57	CAP CER 0.1uF 20% 50V	04222	SR215E104MAA	224268000
C44-45	CAP EL 2200uF 20% 35V	57582	KSM-2200-35	283351000
C46	CAP EL 4700uF 20% 16V	54217	SM-16-VB-4700M	283352000
C47	CAP CER 0.001uF 10% 100V	04222	SR151C102KAA	224270000
C48-49	CAP MICA 270pF 5% 50V	57582	KD5271J101	205045000
C50-54	CAP TANT 10uF 20% 25V	56289	196D106X0025KA1	283293000
C58	CAP TANT 1.0uF 10% 35V	56289	199D105X9035AA2	283216000
C59-61	CAP CER 0.1uF 20% 50V	04222	SR215E104MAA	224268000
CR1-3	DIODE SIG 1N914	01295	1N914	530058000
CR4-5,	DIODE SIG FDH-300	27014	FDH300	530052000
CR6-7	DIODE BRIDGE RS-401S (FWLD-50)	11961	FWLA-50	532028000
CR8-10,12,	DIODE SIG 1N4001	04713	1N4001	530151000
CR11,13	DIODE ZENER 1N5242B 12V 5%	04713	1N5242B	530146000
CR14-17	DIODE SIG 1N4001	04713	1N4001	530151000
CR18	DIODE ZENER 1N5231B 5.1V 5%	04713	1N5231B	530169000
CR19-22	DIODE SIG FDH-300	27014	FDH300	530052000
D81-4	LED YELLOW DIFF 5082-4684	28480	HLMP-1401	536034000
J8	CONN M 40 CKT HDR DBL ROW .1CT	06776	NSH-40DB-S2-TG	47742240A
J9	CONN M 34 CKT STR LATCH 4 WALL	06776	IDH-34PK2-S3-TG30	47741434A
J10	CONN F 24 CKT RT ANGLE PC MTG	00779	553119-1	47947824A
J11-12	CONNECTOR 20 PIN STRAIGHT	27264	22-03-2201	477397000
J15	HEADER 5 PIN STRAIGHT	06383	MPSS156-5-D	477345000
Q1	TRANS PNP 2N4403	04713	2N4403	528122000
R1,5	RES NETWORK 3.3K 2% 1.5W 10pin	71450	750-101-R3.3K	345030000
R2	RES MF 100 OHM 1% 1/4W	19701	5043ED100ROF	341200000
R3	RES MF 1.00K 1% 1/4W	19701	5043ED1K00OF	341300000
R4,6	RES MF 332 OHM 1% 1/4W	19701	5043ED332ROF	341250000
R7	RES NETWORK 3K/6.2K 2% 2.7W	73138	L105-5-R3K/6.2K	345031000
R8	RES MF 56.2K 1% 1/4W	19701	5043ED56K2OF	341472000
R9,20	RES MF 2.00K 1% 1/4W	19701	5043ED2K00OF	341329000
R10-13,	RES MF 5.000K 0.1% 1/8W	64537	PME55-T9	324326000
R14	RES MF 301 OHM 1% 1/4W	19701	5043ED301ROF	341246000
R15	RES NETWORK 10K .1% 1.5W 16pin	73138	698-3R10KD	345010000
R16-17	RES MF 1.65K 1% 1/4W	19701	5043ED1K65OF	341321000
R18-19	RES MF 6.81K 1% 1/4W	19701	5043ED6K81OF	341380000
R21-22	RES MF 5.000K 0.1% 1/8W	64537	PME55-T9	324326000
R60-61	RES MF 5.000K 0.1% 1/8W	64537	PME55-T9	324326000
S1	SWITCH ROCKER (8 SW)	81073	76S808S	465283000
TP1-26	TERMINAL WIRE LOOP TEST POINT	31313	TP-103-02	48330600A
U1	IC 74F139 DUAL 1 OF 4 DECODER	07263	74F139PC	53448000A
U2	IC PAL CONTROL 18CV8			53464500A
U3	IC 74LS148 8 TO 3 LINE ENCODER	01295	SN74LS148N	534234000
U4	IC 74HCT03 QUAD 2 INPUT NAND	18324	74HCT03N	53444212A
U5	IC 74HCT02 QUAD 2 INPUT NOR	18324	74HCT02N	53444211A
U6	IC 74LS93 DIVIDE BY 16 COUNTER	01295	SN74LS93N	534230000
U7	IC 7705 SUPPLY VOLTAGE SUPVR	01295	TL7705ACP	53442200A
U8	IC 68HC000CP	HITAC	HD68HC000CP-10	53449200A
U9,14	IC 74HCT00 QUAD NAND	02735	CD74HCT00E	53444207A
U10	IC EPROM 7200 PROG 1			534590008
U11	IC EPROM 7200 PROG 2			534591008
U12-13	IC TC 55257 PL-10	TOSHI	TC55257APL-10	53449400A
U15	IC EEPROM 28C64 CMOS 200ns	04901	53451000A	53451000A
U16,21	IC 74LS541 OCTAL BUFFER	01295	SN74LS541N	534381000
U17	IC PEEL 153 7200 PROG			53464400A
U18	IC 7673 AUTO BATTERY BACKUP SW	32293	ICL7673CPA	53448500A
U19,23	IC 74LS138 DECDR/MPX	01295	SN74LS138N	534246000
U20	IC 74LS645 TRANSCEIVER	01295	SN74LS645N	534382000

07231000C		REV: AH PWA '7200' CONTROL (CONT.)		
MODEL: 7200				
REFERENCE		FED.	MANUFACTURER	BEC
DESIGNATOR	DESCRIPTION	CODE	PART NUMBER	PART NUMBER
U22	IC 74LS244 OCT BUFF&LINE DRVR	01295	SN74LS244N	534247000
U24,26	IC 74HCT574 OCTAL LATCH	02735	CD74HCT574E	53444215A
U25,27,39	IC DAC725JP DUAL D/A CONVERTER	13919	DAC725JP	53514500A
U28	IC AD7582KN 12 BIT A/D	24355	AD7582KN	53512800A
U29	IC 9914ANL IEEE BUS PROCESSOR	01295	TMS9914ANL	534288000
U30	IC OP-07EP OP AMP	06665	OP-07EP	535110000
U31	IC 75160 IEEE BUS TRANSCEIVER	01295	SN75160BN	534286000
U32	IC 75161 IEEE BUS TRANSCEIVER	01295	SN75161BN	534287000
U33-35	IC UA7806UC VOLT REG	07263	UA7806UC	53511700A
U36	IC 79M05 VOLT REG	07263	UA79M05AUC	535093000
U37	IC TL072BCP DUAL OP AMP	01295	TL072BCP	535102000
U38	IC AD581JH VOLT REF	51640	AD581JH	535053000
U40-41	IC 7406 HEX INVERTER	01295	SN7406N	534067000
XR15	SOCKET IC 16 PIN	06776	ICN-163-S3-G	473042000
XS1	SOCKET IC 16 PIN	06776	ICN-163-S3-G	473042000
XU1,3,19,	SOCKET IC 16 PIN	06776	ICN-163-S3-G	473042000
XU2,16-17,	SOCKET IC 20 PIN	06776	ICN-203-S3-G	473065000
XU4-6,9,14	SOCKET IC 14 PIN	06776	ICN-143-S3-G	473019000
XU7,18,30,	SOCKET IC 8 PIN	06776	ICN-083-S3-G	473041000
XU8	SOCKET IC 68 PIN CER CHIP CARR	32575	641749-2	47308168A
XU10-13,15	SOCKET IC 28 PIN	06776	ICN-286-S4-G	473044000
XU20-22,24	SOCKET IC 20 PIN	06776	ICN-203-S3-G	473065000
XU23	SOCKET IC 16 PIN	06776	ICN-163-S3-G	473042000
XU25,27-28	SOCKET IC 28 PIN	06776	ICN-286-S4-G	473044000
XU26,31-32	SOCKET IC 20 PIN	06776	ICN-203-S3-G	473065000
XU29	SOCKET IC 40 PIN	06776	ICN-406-S4-TG	473052000
XU37	SOCKET IC 8 PIN	06776	ICN-083-S3-G	473041000
XU38	SOCKET TRANSISTOR 3 CIR TO-18	EMC	7003-265-5	47307800A
XU39	SOCKET IC 28 PIN	06776	ICN-286-S4-G	473044000
XU40-41	SOCKET IC 14 PIN	06776	ICN-143-S3-G	473019000
Y1	CRYSTAL OSC 18.432 MHz TTL DIP NDK		TD1100C18.432	54790502A

07231200A		REV: DD PWA '7200' DETECTOR		
MODEL: 7200				
REFERENCE		FED.	MANUFACTURER	BEC
DESIGNATOR	DESCRIPTION	CODE	PART NUMBER	PART NUMBER
C2	CAP MICA 200pF 1% 100V	14655	CD6FA201F	205041000
C3	CAP MICA 56pF 5% 300V	14655	CD6EC560J	205031000
C4-5,7-8,	CAP CER 1.0uF 20% 50V	04222	SR305E105MAA	224264000
C10,23-24	CAP MICA 680pF 1% 300V	14655	CD15FC681F03	200015000
C11-14,	CAP CER 1.0uF 20% 50V	04222	SR305E105MAA	224264000
C15-16	CAP MICA 39pF 5% 300V	14655	CD6EC390J	205044000
C21-22	CAP MICA 1000pF 1% 100V	51406	DM15-102F	200113000
C25-26	CAP CER 1.0uF 20% 50V	04222	SR305E105MAA	224264000
CR1-2	DIODE DKV6522A	31091	DKV6522A	530769000
CR5	DIODE HSCH1001 (1N6263)	28480	HSCH-1001	530174000
J1-11	SOCKET SPRING COMP LEAD .072	32575	1-332070-7	479333000
L1	INDUCTOR 2.2mH	00213	WEE2200	400141000
Q1	TRANS NPN 2N3904	04713	2N3904	528071000
Q2	TRANS PNP 2N3906	04713	2N3906	528076000
R3	RES MF 100 OHM 1% 1/4W	19701	5043ED100R0F	341200000
R4-5,25	RES MF 200 OHM 0.1% 1/8W	64537	PME55-T9	324162000
R6	RES MF 845 OHM 1% 1/4W	19701	5043ED845R0F	341289000
R12	RES MF 499 OHM 1% 1/4W	19701	5043ED499R0F	341267000
R13,36	RES MF 2.49K 1% 1/4W	19701	5043ED2K490F	341338000
R14	RES MF 683.8 OHM 0.1% 1/8W	91637	CMF-55-683R8-B-T9	32422300A
R15,31,34	RES MF 100 OHM 0.1% 1/8W	64537	PME55-T9	324118000
R16	RES MF 2.00K 1% 1/4W	19701	5043ED2K000F	341329000
R18-19,44	RES MF 10.0K 1% 1/4W	19701	5043ED10K00F	341400000

07231200A REV: DD PWA '7200' DETECTOR (CONT.)
MODEL: 7200

REFERENCE DESIGNATOR	DESCRIPTION	FED. CODE	MANUFACTURER PART NUMBER	BEC PART NUMBER
R26	RES VAR 5K 10% 0.5W	73138	72PR5K	311308000
R29,37	RES MF 20.00K 0.1% 1/8W	03888	PME55-T9	32591800A
R30,R33	RES VAR 500 OHM 10% 0.5W	73138	68WR500	31142500A
R32,38	RES MF 2.000K 0.1% 1/8W	64537	PME55-T9	324275000
R35	RES MF 4.99K 1% 1/4W	19701	5043ED4K990F	341367000
R39-40	RES MF 10.5K 1% 1/4W	19701	5043ED10K50F	341402000
R41-42	RES MF 5.62K 1% 1/4W	19701	5043ED5K620F	341372000
R43	RES MF 557.4 OHM 0.1% 1/8W	64537	PME55-T9	325901000
R45	RES VAR 500 OHM 10% 0.5W	73138	72PR500	311306000
RT1	THERMISTOR 1K 1%	94322	Q81	325006000
T1	XFORMER RF (TT1-6-X65)	15542	TT1-6 STYLE X65	41009401A
TP2,5-11	TERMINAL WIRE LOOP TEST POINT	31313	TP-103-02	48330600A
U1	IC 419 ANALOG SWITCH	17856	DG-419-DJ	53452400A
U6-7	IC MPY634KP 4 QUAD ANALOG MULT	13919	MPY634KP	53451900A
U8-9	(G) IC 3568 OP AMP SELECTED	04901	535062000	535062000
U10	IC 592 TEMPERATURE TRANSDUCER	51640	AD592AN	53514700A
XU1,8-9	SOCKET IC 8 PIN	06776	ICN-083-S3-G	473041000
XU6-7	SOCKET IC 14 PIN	06776	ICN-143-S3-G	473019000

07231300B REV: CD PWA '7200' MOTHER
MODEL: 7200

REFERENCE DESIGNATOR	DESCRIPTION	FED. CODE	MANUFACTURER PART NUMBER	BEC PART NUMBER
C1,12	CAP TANT 10uF 10% 35V	56289	196D106X903PE4	283353000
C2,7	CAP EL 100uF 20% 25V	54217	SM-25-VB-101M	283334000
C3-4,8-9	CAP CER 1.0uF 20% 50V	04222	SR305E105MAA	224264000
C5-6	CAP CER 0.22uF 10% 200V	61637	C340C224M2R5CA	22439200A
C10	CAP CER 0.1uF 20% 50V	04222	SR215E104MAA	224268000
C11	CAP CER 0.001uF 500V TOL	33883	BG Z5U GMV	224114000
CR1-9	DIODE SIG 1N914	01295	1N914	530058000
F1	FUSE 3/10A (0.3A) 125V MICRO	75915	273.300	54554212A
FH1	FUSEHOLDER PWB VERT MOUNT	75915	281005	48211801A
J1-2	CONNECTOR 20 PIN	27264	22-02-2205	479399000
J3	CONN M 06 CKT ST POLZ .1CT	06383	MPSS100-6-A	47740706A
J4-32	SOCKET SPRING COMP LEAD .072	32575	1-332070-7	479333000
K1-2	RELAY REED 15V PSEUDO FORM "C"	18542	1632-3-1	47104800A
L1	INDUCTOR 560uH 5%	00213	WEE-560	400183000
Q1	TRANS NPN D44H11	04713	D44H11	52816100A
Q2	TRANS PNP MPS-U60	04713	MPSU60	528096000
Q3	TRANS NPN MPS-U10	04713	MPSU10	528097000
Q4	TRANS PNP 2N3906	04713	2N3906	528076000
Q5	TRANS NPN 2N3904	04713	2N3904	528071000
Q6	TRANS NPN MM3001	04713	MM3001	528140000
Q7	TRANS PNP MM4001	04713	MM4001	528141000
R1,4	RES MF 1.00K 1% 1/4W	19701	5043ED1K000F	341300000
R2-3	RES MF 33.2 OHM 1% 1/4W	19701	5043ED33R20F	341150000
R5-6,9-12	RES MF 10.0K 1% 1/4W	19701	5043ED10K00F	341400000
R7-8	RES MF 5.11K 1% 1/4W	19701	5043ED5K110F	341368000
R13	RES MF 681 OHM 1% 1/4W	19701	5043ED681R0F	341280000
R14	RES MF 200 OHM 1% 1/4W	19701	5043ED200R0F	341229000
R15	RES MF 500.0K 0.1% 1/2W	64537	PME60-T9	340564000
R17	RES MF 40.00K 0.1% 1/8W	64537	PME55-T9	32591900A
R18	RES MF 160.0K 0.1% 1/8W	64537	PME55-T9	32592100A
R20-21	RES MF 4.000K 0.1% 1/8W	64537	PME55-T9	324313000
R22	RES MF 1.000K 0.1% 1/8W	64537	PME55-T9	324241000
R24	RES MF 806 OHM 1% 1/4W	19701	5043ED806R0F	341287000

07231300B REV: CD PWA '7200' MOTHER
MODEL: 7200

<u>REFERENCE DESIGNATOR</u>	<u>DESCRIPTION</u>	<u>FED. CODE</u>	<u>MANUFACTURER PART NUMBER</u>	<u>BEC PART NUMBER</u>
R25,27,35	RES MF 2.44K 0.1% 1/8W	64537	PME55-T9	32594600A
R26,28,36	RES MF 1.69K 0.1% 1/8W	64537	PME55-T9	32594500A
R31	RES NETWORK 22K 2% 1.5W	71450	750-61-R22K	345037000
R32-33	RES MF 243 OHM 1% 1/4W	19701	5043ED243ROF	341237000
R34	RES MF 20.0K 1% 1/4W	19701	5043ED20K00F	341429000
R37	RES MF 4.99K 1% 1/4W	19701	5043ED4K990F	341367000
R38	RES MF 2.49K 1% 1/4W	19701	5043ED2K490F	341338000
U1	IC 1013 DUAL PRCN OPAMP 8 DIP			53512400A
U2	IC 419 ANALOG SWITCH	17856	DG-419-DJ	53452400A
XU1-2	SOCKET IC 8 PIN	06776	ICN-083-S3-G	473041000

07231500B REV: BB '7200' HOUSING DETECTOR ASSY
MODEL: 7200

<u>REFERENCE DESIGNATOR</u>	<u>DESCRIPTION</u>	<u>FED. CODE</u>	<u>MANUFACTURER PART NUMBER</u>	<u>BEC PART NUMBER</u>
C1-15,	CAP FT 3000pF 100V	32575	859617-1	227123000
C16	CAP FT 2000pF MIN 300V			22712500A
C17-23	CAP FT 3000pF 100V	32575	859617-1	227123000
J1-3,11-14	CONNECTOR "SMB" 50 OHM	19505	2019-7511-000	477305000
W2	CABLE ASSY WIRE 24GA 3.50L YEL			57125503A
W4	CABLE ASSY WIRE 24GA 3.50L BRN			57125501A
W5	CABLE ASSY WIRE 24GA 3.00L VIO			57125505A
W8	CABLE ASSY WIRE 24GA 3.87L RED			57125502A
W9	CABLE ASSY WIRE 24GA 2.12L WHT			57125507A
W12	CABLE ASSY WIRE 24GA 2.12L GRN			57125504A
W18	CABLE ASSY WIRE 24GA 1.50L GRN			57125506A

07231800A REV: AA '7200' HOUSING ASSY
MODEL: 7200

<u>REFERENCE DESIGNATOR</u>	<u>DESCRIPTION</u>	<u>FED. CODE</u>	<u>MANUFACTURER PART NUMBER</u>	<u>BEC PART NUMBER</u>
J4-7	CONN F COAX BNC	54420	UG-625B/U	479123000
T1	'7200' TOROID TEST ASSY			07232400A

07231900A REV: AA '7200' COVER ASSY
MODEL: 7200

<u>REFERENCE DESIGNATOR</u>	<u>DESCRIPTION</u>	<u>FED. CODE</u>	<u>MANUFACTURER PART NUMBER</u>	<u>BEC PART NUMBER</u>
J10	CONNECTOR "SMB" 50 OHM	19505	2019-7511-000	477305000

07232000A MODEL: 7200		REV: AA '7200' SHIELD ASSY		
<u>REFERENCE DESIGNATOR</u>	<u>DESCRIPTION</u>	<u>FED. CODE</u>	<u>MANUFACTURER PART NUMBER</u>	<u>BEC PART NUMBER</u>
J8-9	CONNECTOR "SMB" 50 OHM	19505	2019-7511-000	477305000
R1	RES MF 49.9 OHM 1% 1/4W	19701	5043ED49R90F	341167000

07236000A MODEL: 7200		REV: AA FRONT PANEL ASSY 7200		
<u>REFERENCE DESIGNATOR</u>	<u>DESCRIPTION</u>	<u>FED. CODE</u>	<u>MANUFACTURER PART NUMBER</u>	<u>BEC PART NUMBER</u>
A2A1	PWA DISPLAY '7200'			07236100A
J19	CONNECTOR BINDING POST GROUND	74970	111-2223-001	47945400A

07236100A MODEL: 7200		REV: DC PWA DISPLAY '7200'		
<u>REFERENCE DESIGNATOR</u>	<u>DESCRIPTION</u>	<u>FED. CODE</u>	<u>MANUFACTURER PART NUMBER</u>	<u>BEC PART NUMBER</u>
C1	CAP EL 100uF 20% 25V	34217	SM-25-VB-101M	283334000
C2-5	CAP CER 0.1uF 20% 50V	04222	SR215E104MAA	224268000
J1	CONN 20 PIN STR DBL ROW			47952120A
J2	CONN 3 PIN STR PWB MTG			47952003A
J5	CONN M 34 CKT HDR DBL ROW .1CT			47742234A
P2	HEADER 22 PIN STR			47747722A
R1	RES MF 3.32K 1% 1/4W	19701	5043ED3K320F	341350000
R2	RES NETWORK 3.3K 2% 1.5W 10pin	71450	750-101-R3.3K	345030000
R3	RES NETWORK 22 OHM +-2 OHM 2W	01121	316B-220	345034000
U1	IC 74LS86 GATE EXCLUSIVE OR	01295	SN74LS86N	53447400A
U2	IC 74LS245 OCT BUS TRANSCIVER	01295	SN74LS245N	53437200A
U3	IC 74LS155 DUAL 2-4 LINE DECOD	01295	SN74LS155AN	53447500A
U4	IC 8279-2 KEYBD/DISP INTERFACE	33297	UPD8279C-2	534211000
U5	IC 2985 HIGH OUTPUT BUFFER	56289	UDN2985A	53447900A
U6	IC 590 ADDRESSABLE PERIPH DRIV			53472200A
U7	IC 74LS138 DECDR/MPX	01295	SN74LS138N	534246000
XU4	SOCKET IC 40 PIN LOW PROFILE	06776	ICT-406-S-TG	473068000

07643200A MODEL: 7600		REV: BD PWA '7600' H.V. POWER SUPPLY		
<u>REFERENCE DESIGNATOR</u>	<u>DESCRIPTION</u>	<u>FED. CODE</u>	<u>MANUFACTURER PART NUMBER</u>	<u>BEC PART NUMBER</u>
C1	CAP TANT 22uF 10% 35V	56289	196D226X9035PE4	283308000
C2	CAP CER 0.001uF 10% 100V	04222	SR151C102KAA	224270000
C3,10-12	CAP CER 0.01uF 10% 100V	04222	SR201C103KAA	224269000
C4	CAP MICA 100pF 5% 300V	20307	DM5-FC101J	205006000

07643200A REV: BD PWA '7600' H.V. POWER SUPPLY (Conf.)
MODEL: 7600

REFERENCE DESIGNATOR	DESCRIPTION	FED. CODE	MANUFACTURER PART NUMBER	BEC PART NUMBER
C5-8	CAP EL 4.7uF 20% 250V	19701	3476GD479M250JMBS	28336200A
C9	CAP TANT 10uF 20% 25V	56289	196D106X0025KA1	283293000
CR1-5	DIODE SIG 1N4936	04713	1N4936	53019000A
CR6-7	DIODE SIG 1N914	01295	1N914	530068000
L1-2	INDUCTOR 1.2mH 5% 76A/103	24226	22/124	400380000
P1-6	TERMINAL .040 OD .270 LG .062M	98291	229-1071-000-230	510038000
Q1	TRANS PNP D45H11	04713	D45H11	52816200A
R1	RES MF 243 OHM 1% 1/4W	19701	5043ED243R0F	341237000
R2	RES MF 7.50K 1% 1/4W	19701	5043ED7K500F	341384000
R3	RES MF 1.00M 1% 1/4W	19701	5043ED1M000F	341600000
R4,6	RES MF 100K 1% 1/4W	19701	5043ED100K0F	341500000
R5	RES MF 27.4K 1% 1/4W	19701	5043ED27K40F	341442000
R7	RES MF 10.0K 1% 1/4W	19701	5043ED10K00F	341400000
R8	RES MF 475K 1% 1/4W	19701	5043ED475K0F	341565000
R9	RES MF 221K 1% 1/4W	19701	5043ED221K0F	341533000
T1	XFORMER STEP UP '7600'	04901	44609900A	44609900A
U1	IC TL072CP DUAL OP AMP	01295	TL072CP	535092000
XU1	SOCKET IC 8 PIN	06776	ICN-083-S3-G	473041000
Y1	CRYSTAL 32768 Hz			54703800A

60341600B REV: AA REAR PANEL UNIT '7200'
MODEL: 7200

REFERENCE DESIGNATOR	DESCRIPTION	FED. CODE	MANUFACTURER PART NUMBER	BEC PART NUMBER
S1	SWITCH DUAL SLIDE DPDT-DPDT	82389	47206LFR	465279000

96000301A REV: AA FUSE KIT 220V 0.2A
MODEL: 4200/9200A

REFERENCE DESIGNATOR	DESCRIPTION	FED. CODE	MANUFACTURER PART NUMBER	BEC PART NUMBER
F1	FUSE 2/10A (0.2A) 250V	54426	MDL 0.2	545608000
XF2B	FUSE CARRIER BLACK 5mm x 20mm	SCHUR	FEK031.1663S	482115000

SECTION VII SCHEMATIC DIAGRAMS

Table 7-1. List of Schematics.

Figure	Page
Figure 7-1. Frame Schematic, A1.	7-3
Figure 7-2. Display Board, A2A1, Assembly Diagram.	7-4
Figure 7-3. Display Board Schematic, A2A1.	7-5
Figure 7-4. Keyboard, A2A2, Assembly Diagram.	7-6
Figure 7-5. Keyboard Schematic, A2A2.	7-7
Figure 7-6. Control Board, A3, Assembly Diagram.	7-8
Figure 7-7. Control Board Schematic, A3, Sheet 1.	7-9
Figure 7-8. Control Board Schematic, A3, Sheet 2.	7-11
Figure 7-9. Control Board Schematic, A3, Sheet 3.	7-13
Figure 7-10. Mother Board, A4, Assembly Diagram.	7-14
Figure 7-11. Mother Board Schematic, A4.	7-15
Figure 7-12. H. V. Supply Board, A4A1, Assembly Diagram.	7-16
Figure 7-13. H. V. Supply Board Schematic, A4A1.	7-17
Figure 7-14. Oscillator Board, A5A1, Assembly Diagram.	7-18
Figure 7-15. Oscillator Board Schematic, A5A1.	7-19
Figure 7-16. Detector Board, A5A2, Assembly Diagram.	7-20
Figure 7-17. Detector Board Schematic, A5A2.	7-21
Figure 7-18. Amplifier Board, A5A3, Assembly Diagram.	7-22
Figure 7-19. Amplifier Board Schematic, A5A3.	7-23

A1 FRAME ASSEMBLY

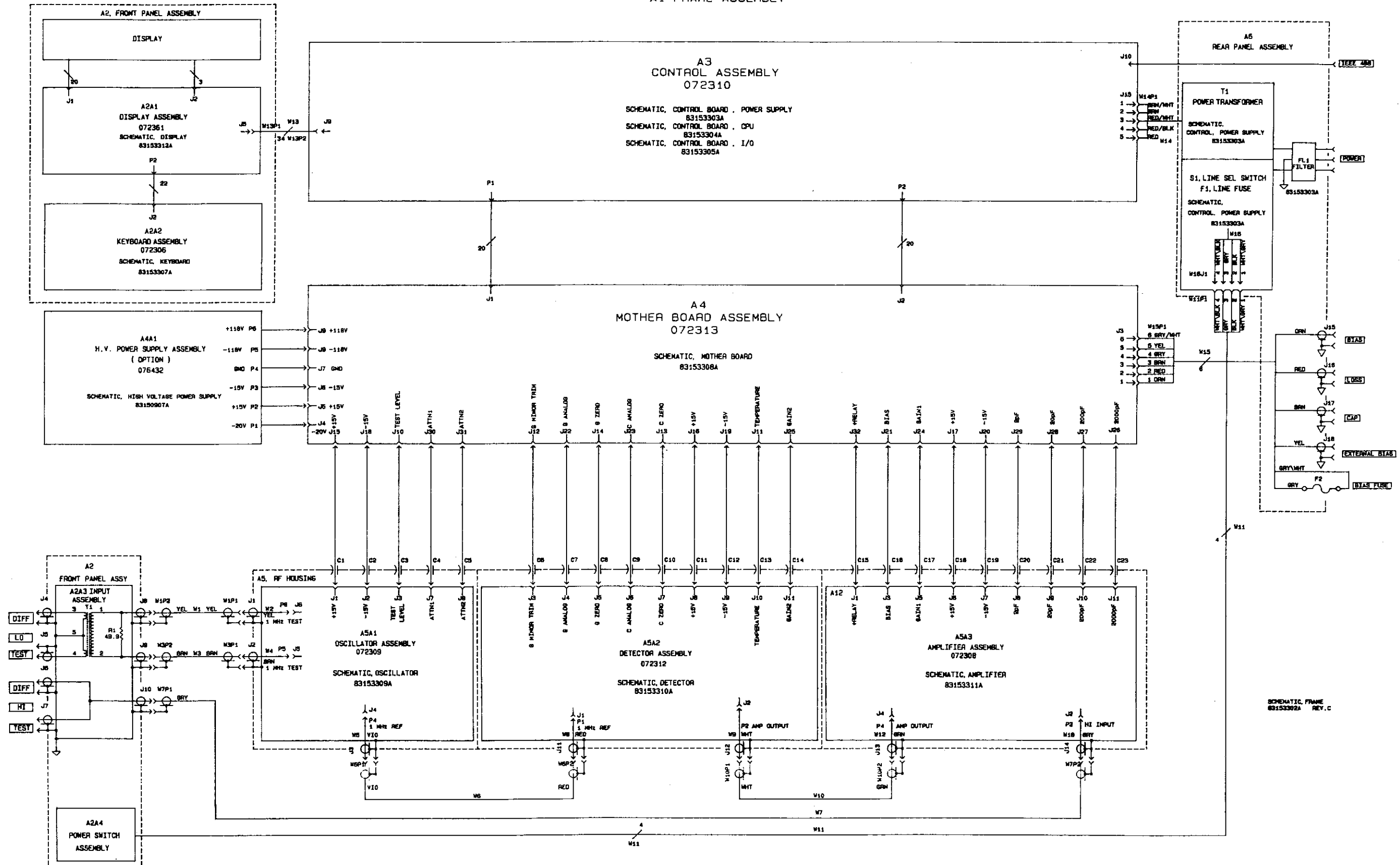
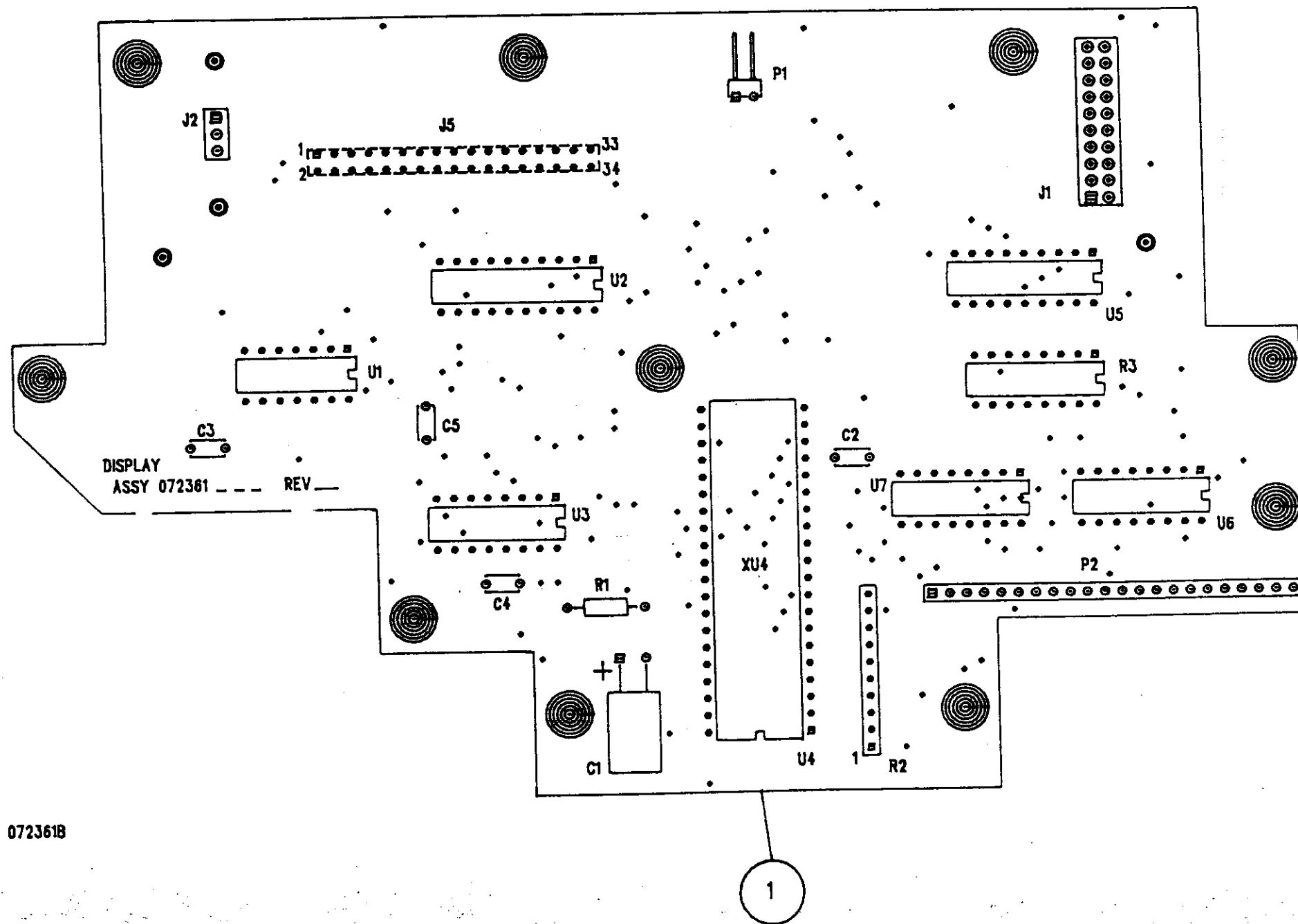

Figure 7-1. Frame Schematic, A1. 7-3



072361B

7-4 Figure 7-2. Display Board, A2A1, Assembly Diagram.

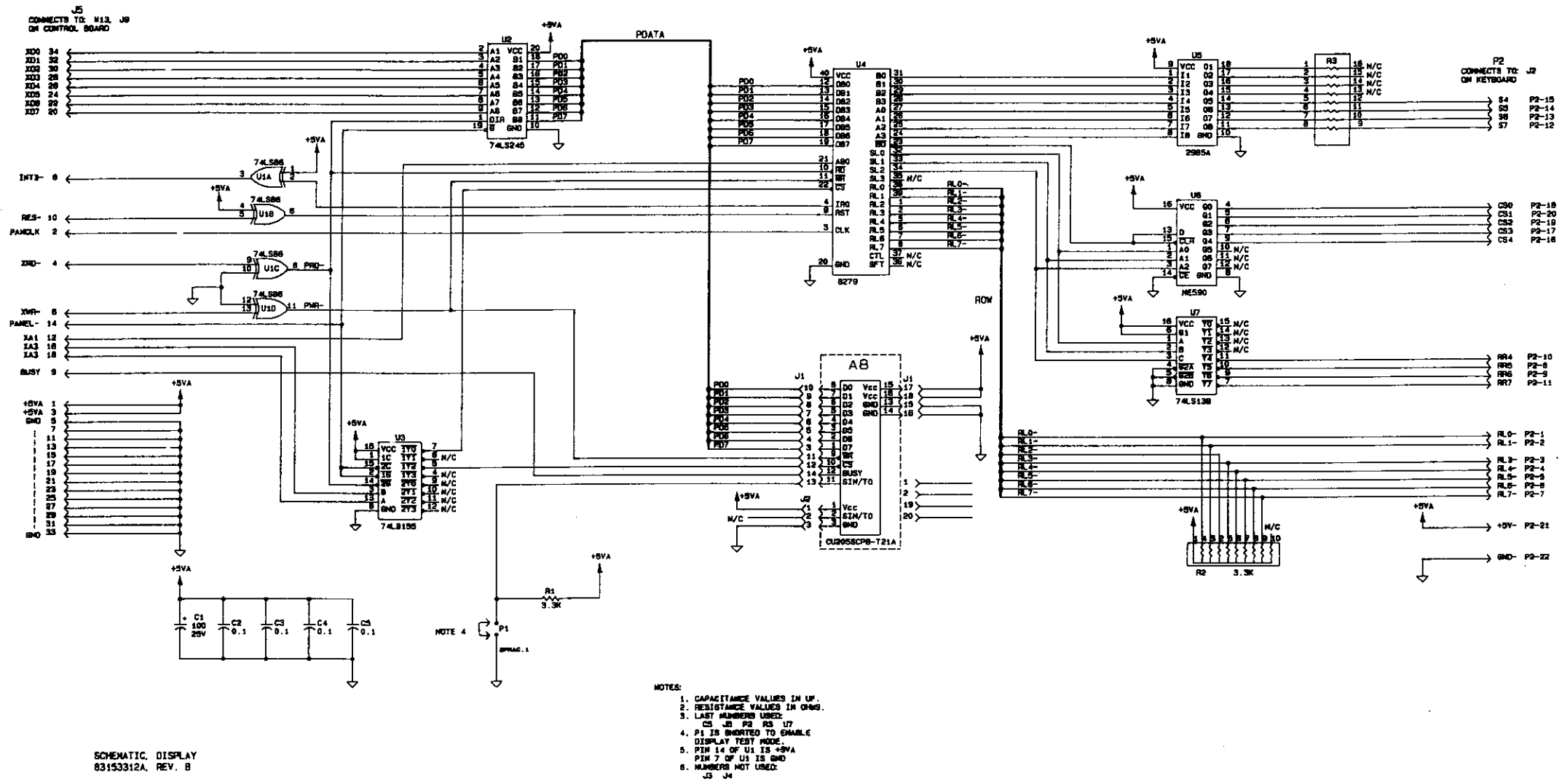
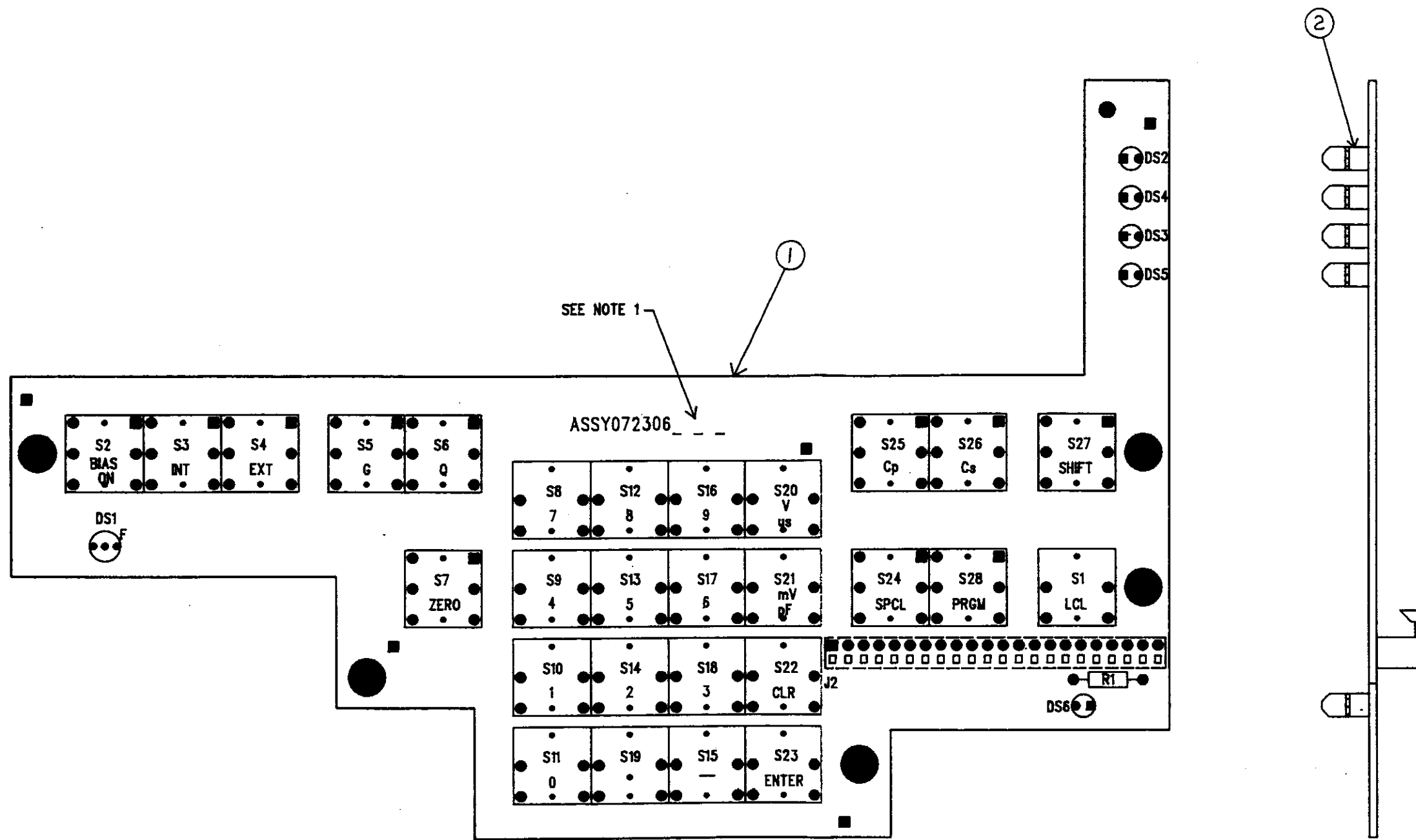

Figure 7-3. Display Board Schematic, A2A1. 7-5



072306C₂

ITEM NO.	LEGEND	ITEM NO.	LEGEND
3	1	17	BIAS/ON
4	2	18	ZERO
5	3	19	LCL
6	4	20	ENTER
7	5	21	CLR
8	6	22	SPCL
9	7	23	EXT
10	8	24	INT
11	9	25	G
12	0	26	Q
13	—	27	Cp
14	•	28	Cs
15	mV/pF	29	SHIFT
16	V/μs	30	PRGM

NOTES:

1. MARK FINAL ASSY PART NUMBER WITH 1/8 HIGH BLACK CHARACTERS REFER TO MANUFACTURING ORDER FOR COMPLETE PART NUMBER.
2. ITEMS 1 (PWB KEYBOARD), 2 (SPACER) 1 ONLY, 18 (BUTTON MARKED), S7 (SWITCH), DS6 (LED), R1 (RESISTOR) AND J2 (CONNECTOR) REQUIRED ON 07230601A (7200-S/1) ONLY.

THIS SHEET SPECIFIES PART NUMBERS 07230600A AND 07230601A

7-6 Figure 7-4. Keyboard, A2A2, Assembly Diagram

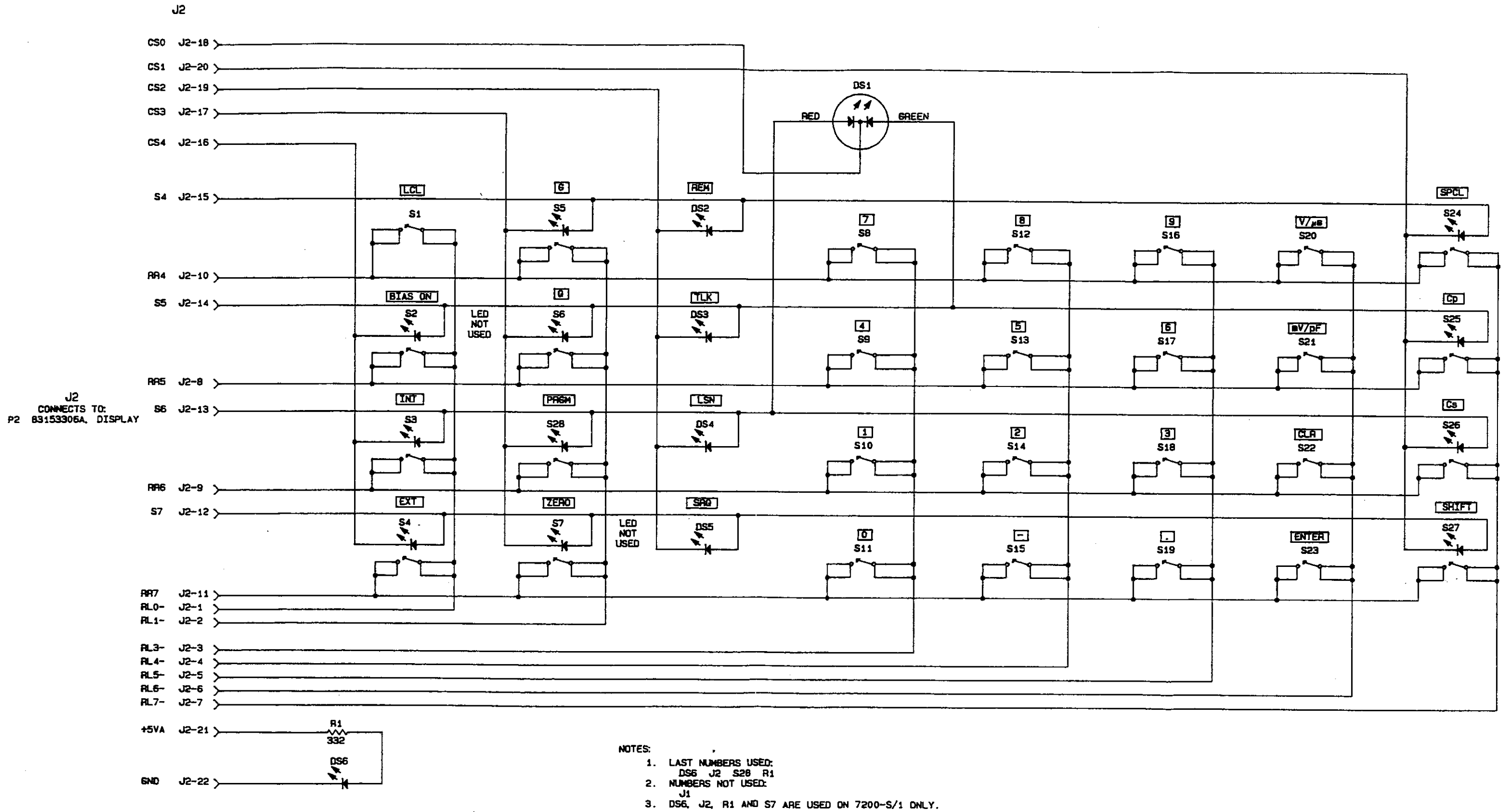

SCHEMATIC, KEYBOARD
83153307A, REV. C1

Figure 7-5. Keyboard Schematic, A2A2. 7-7

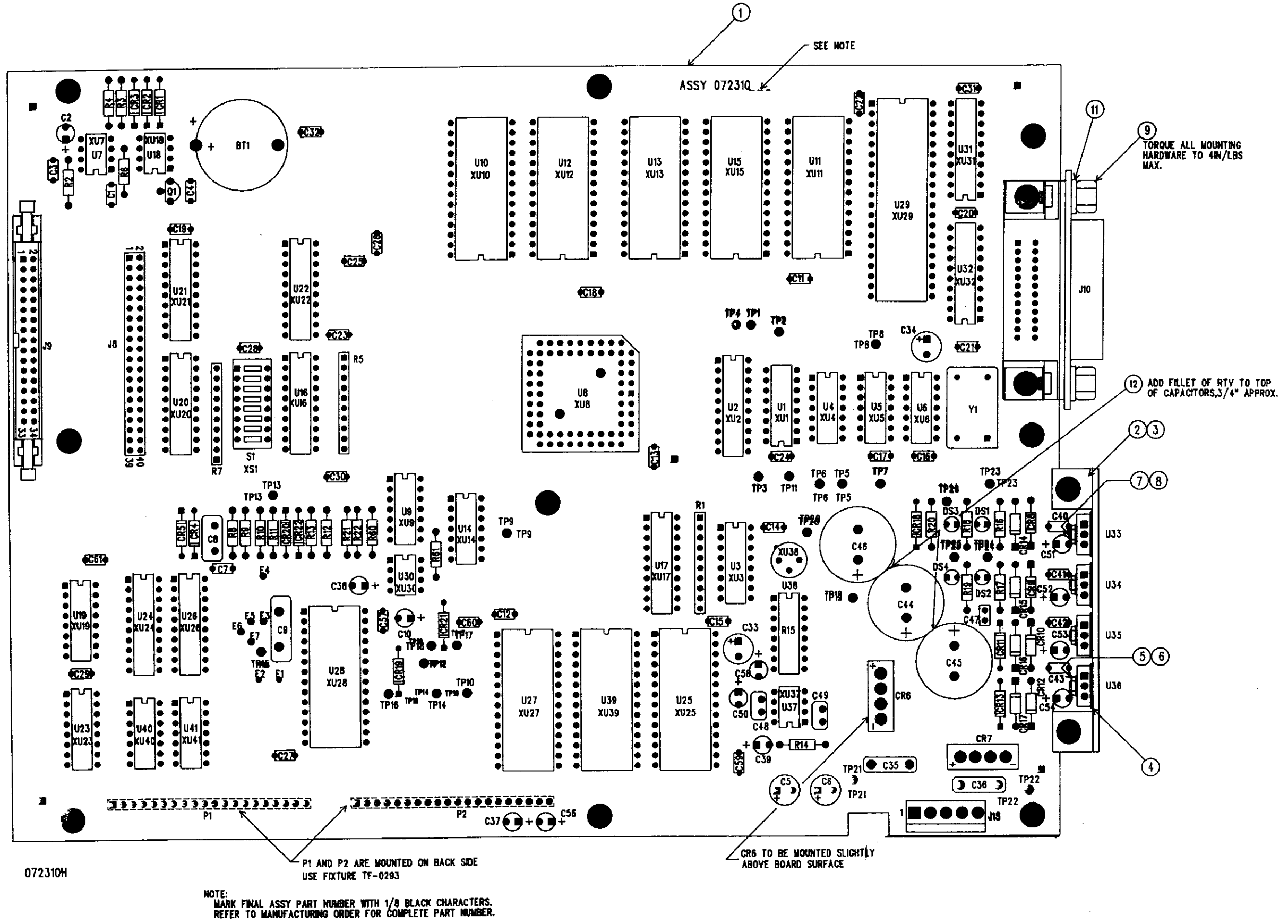

7-8 Figure 7-6. Control Board, A3, Assembly Diagram.

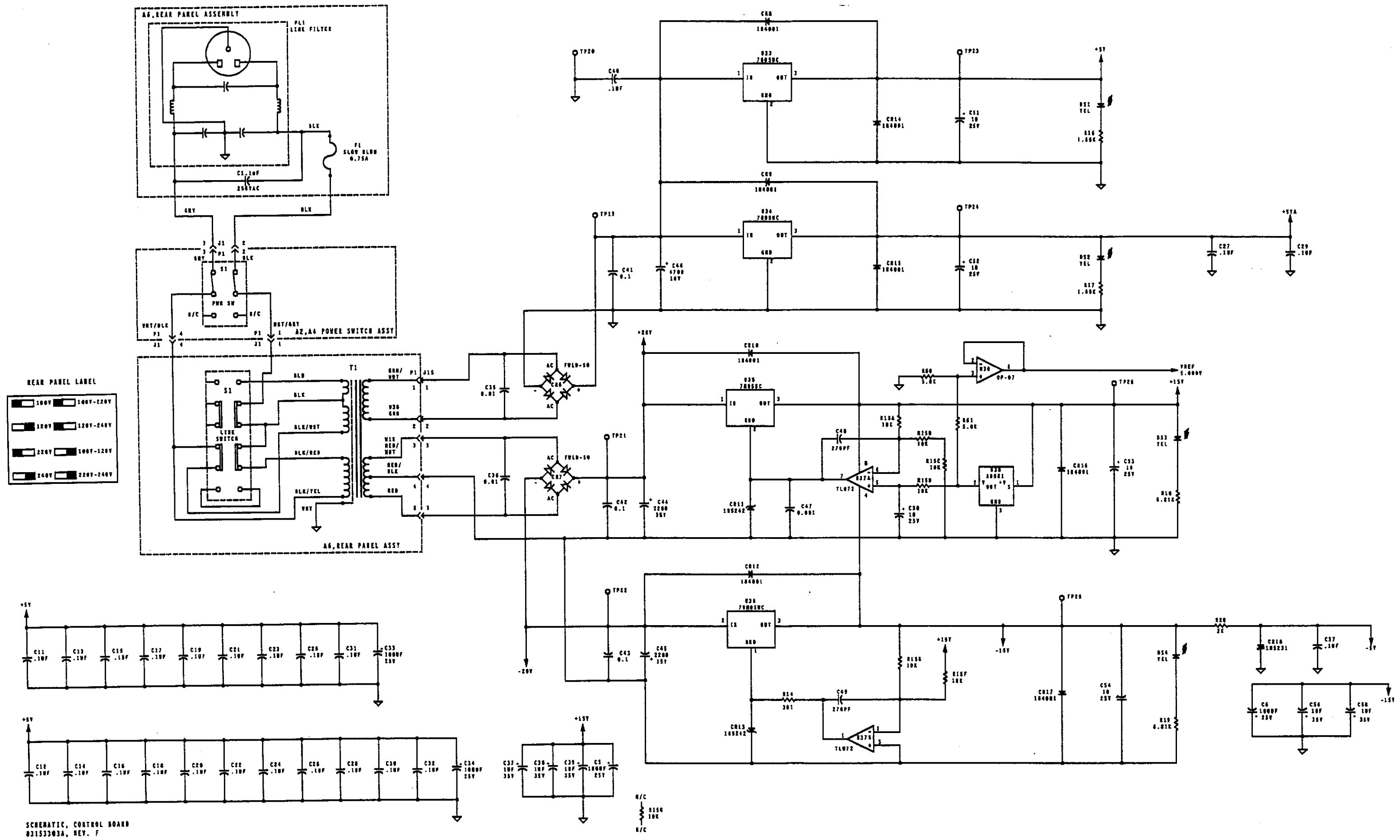

SCHEMATIC, CONTROL BOARD 03153303A, REV. F

Figure 7-7. Control Board Schematic, A3, Sheet 1. 7-9

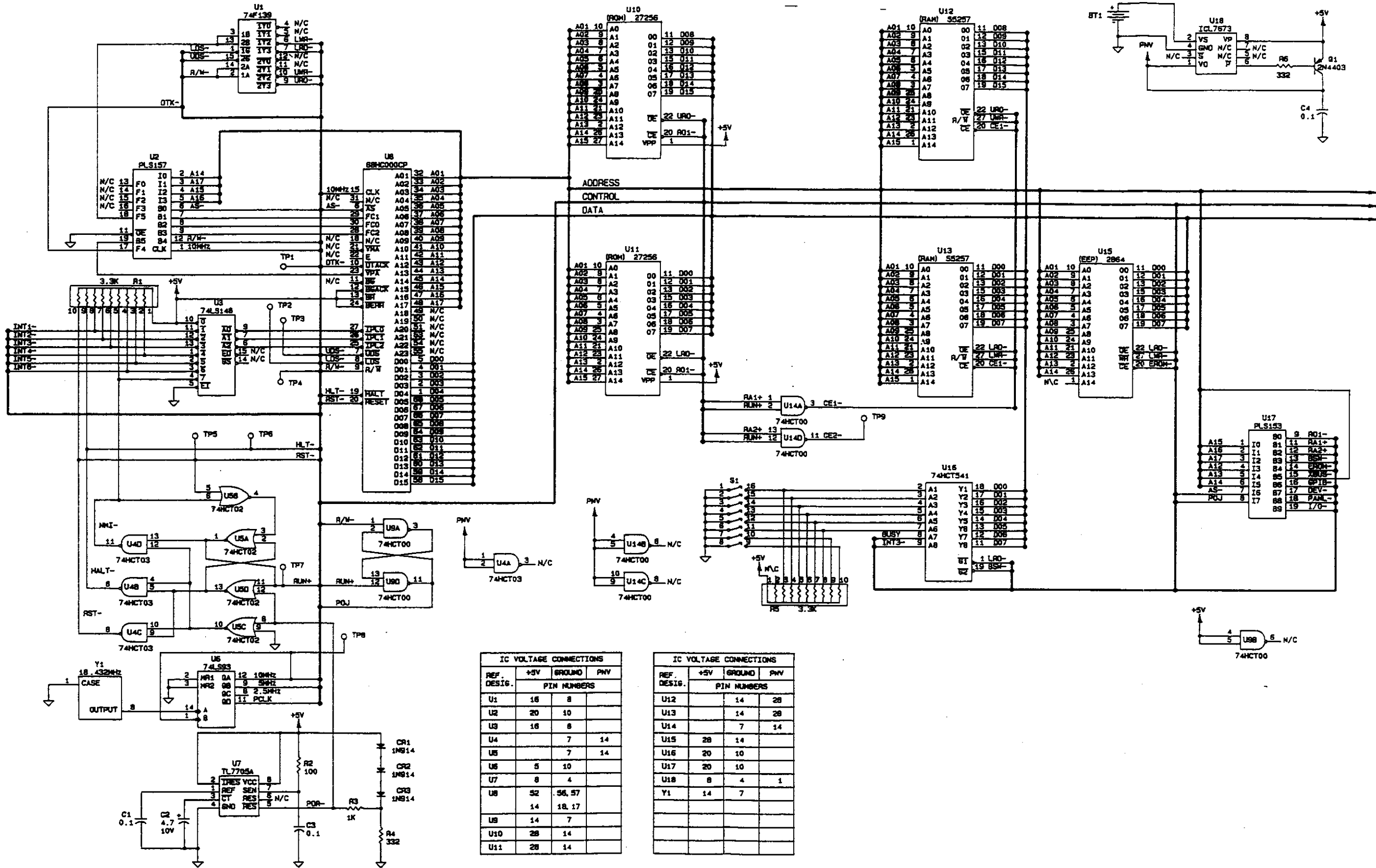

SCHEMATIC, CONTROL BOARD 83153304A, REV. E

- NOTES:
- CAPACITANCE VALUES IN UF, UNLESS OTHERWISE SPECIFIED.
 - RESISTANCE VALUES IN OHMS.
 - LAST NUMBERS USED: BT1, C62, CR22, J19, P2, G1, R61, S1, TP26, U42, Y1
 - NUMBERS NOT USED: J1, J2, J3, J4, J5, J6, J7, J11, J12, J13, J14, J16, J17, J18, J20

Signals To:
Sheet 5
ADDRESS
CONTROL
DATA

Figure 7-8. Control Board Schematic, A3, Sheet 2. 7-11

Signals To:
Sheet 4

DATA
CONTROL
ADDRESS

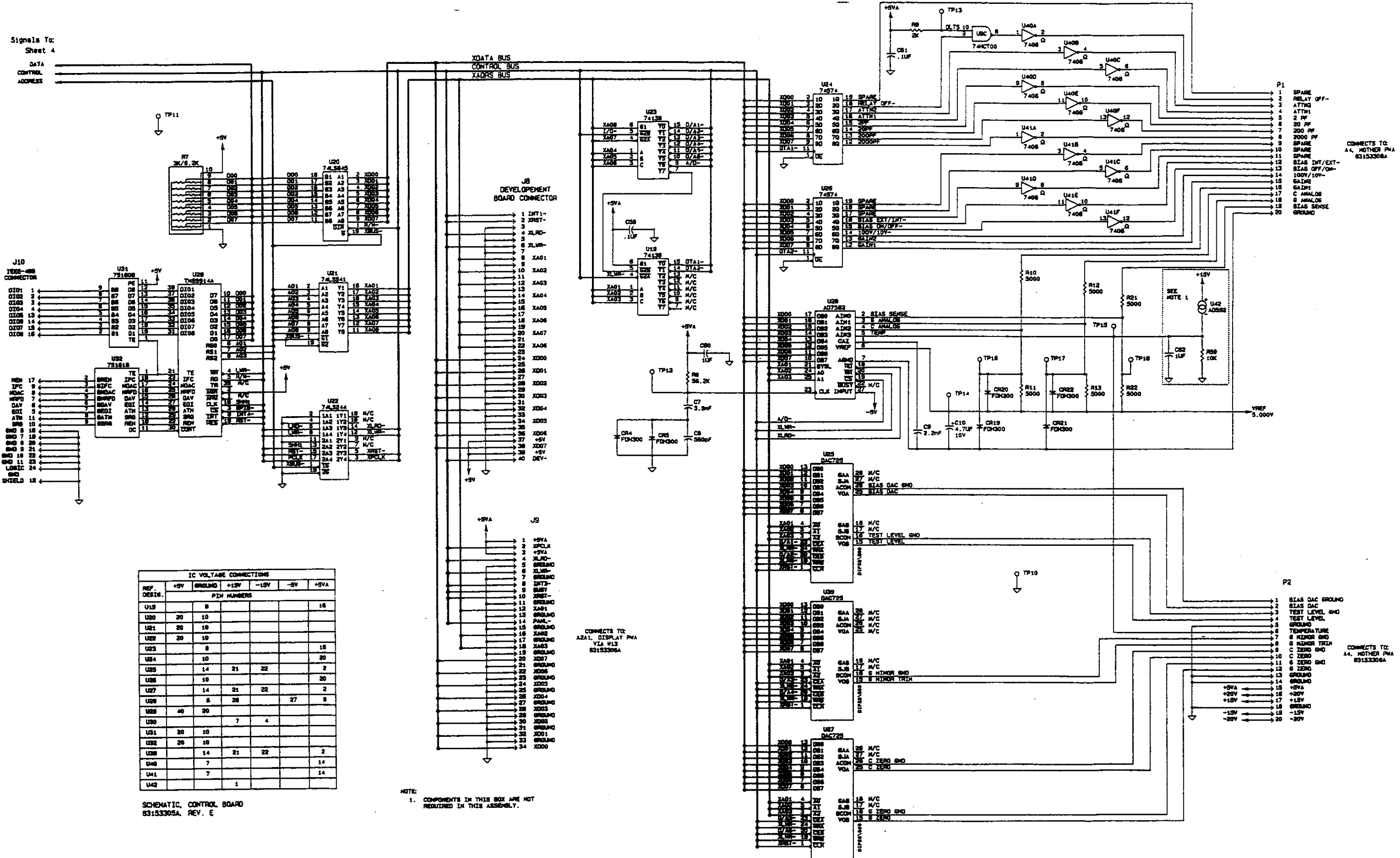

IC VOLTAGE CONNECTIONS

REF. DESIG.	+5V	GROUND	+15V	-15V	-5V	+5VA
U15		8				16
U20	20	10				
U21	20	10				
U22	20	10				
U23						18
U24	10					20
U25	14	21	22			2
U26	19					20
U27	14	21	22			2
U28	8	28			27	9
U29	40	20				
U30		7	4			
U31	20	10				
U32	20	10				
U38	14	21	22			2
U40	7					14
U41	7					14
U42		1				

SCHEMATIC, CONTROL BOARD
83153305A, REV. E

NOTE:
1. COMPONENTS IN THIS BOX ARE NOT REQUIRED IN THIS ASSEMBLY.

Figure 7-9. Control Board Schematic, A3, Sheet 3. 7-13

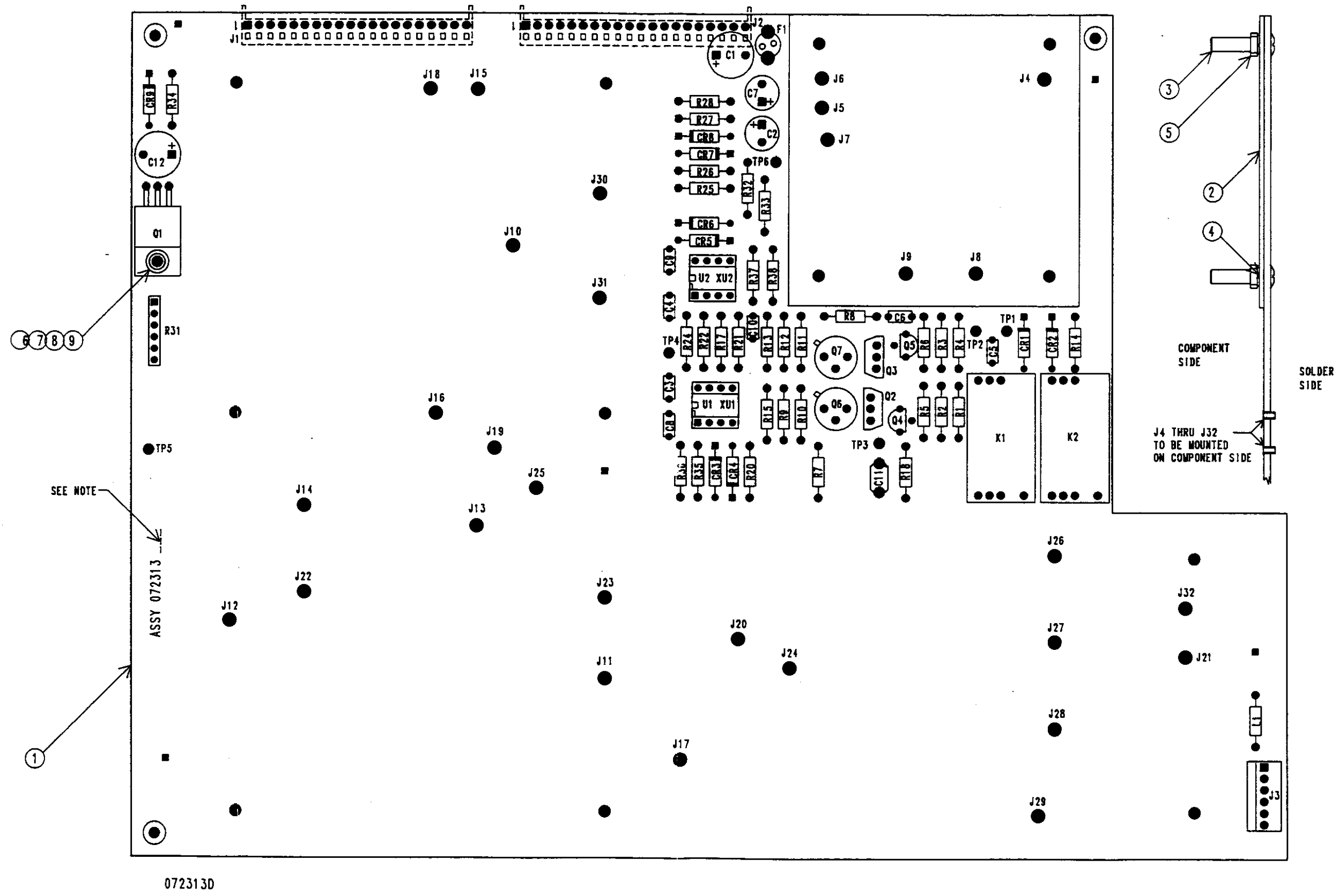

NOTE:
 MARK FINAL ASSY PART NUMBER WITH 1/8 HIGH BLACK CHARACTERS.
 REFER TO MANUFACTURING ORDER FOR COMPLETE PART NUMBER

7-14 Figure 7-10. Mother Board, A4, Assembly Diagram.

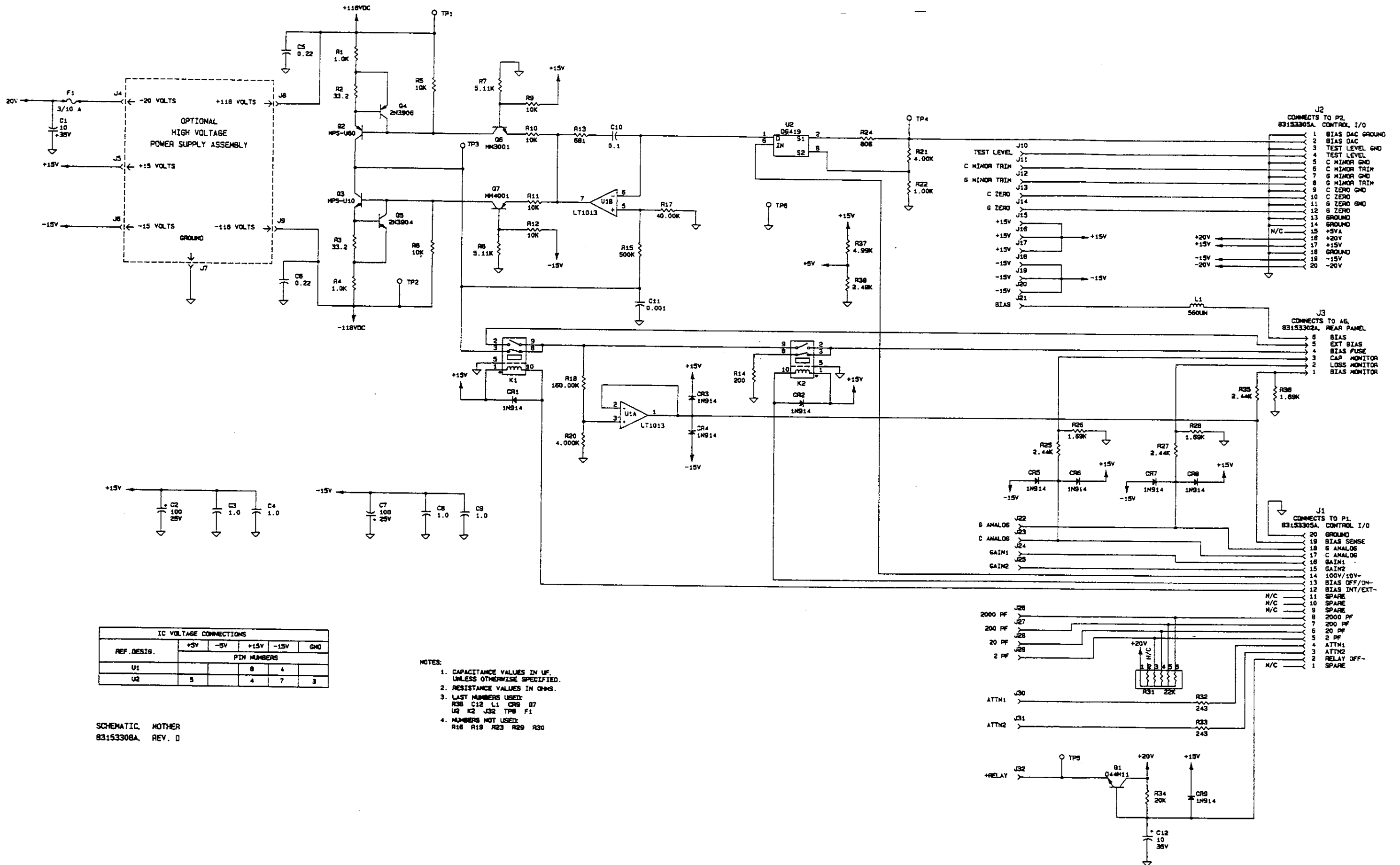

IC VOLTAGE CONNECTIONS					
REF. DESIG.	+5V	-5V	+15V	-15V	GND
	PIN NUMBERS				
U1			8	4	
U2	5		4	7	3

- NOTES:
1. CAPACITANCE VALUES IN UF, UNLESS OTHERWISE SPECIFIED.
 2. RESISTANCE VALUES IN OHMS.
 3. LAST NUMBERS USED:
R36 C12 L1 CR5 Q7
U2 K2 J32 TP8 F1
 4. NUMBERS NOT USED:
R16 R19 R23 R29 R30

SCHEMATIC, MOTHER
83153308A, REV. 0

Figure 7-11. Mother Board Schematic, A4. 7-15

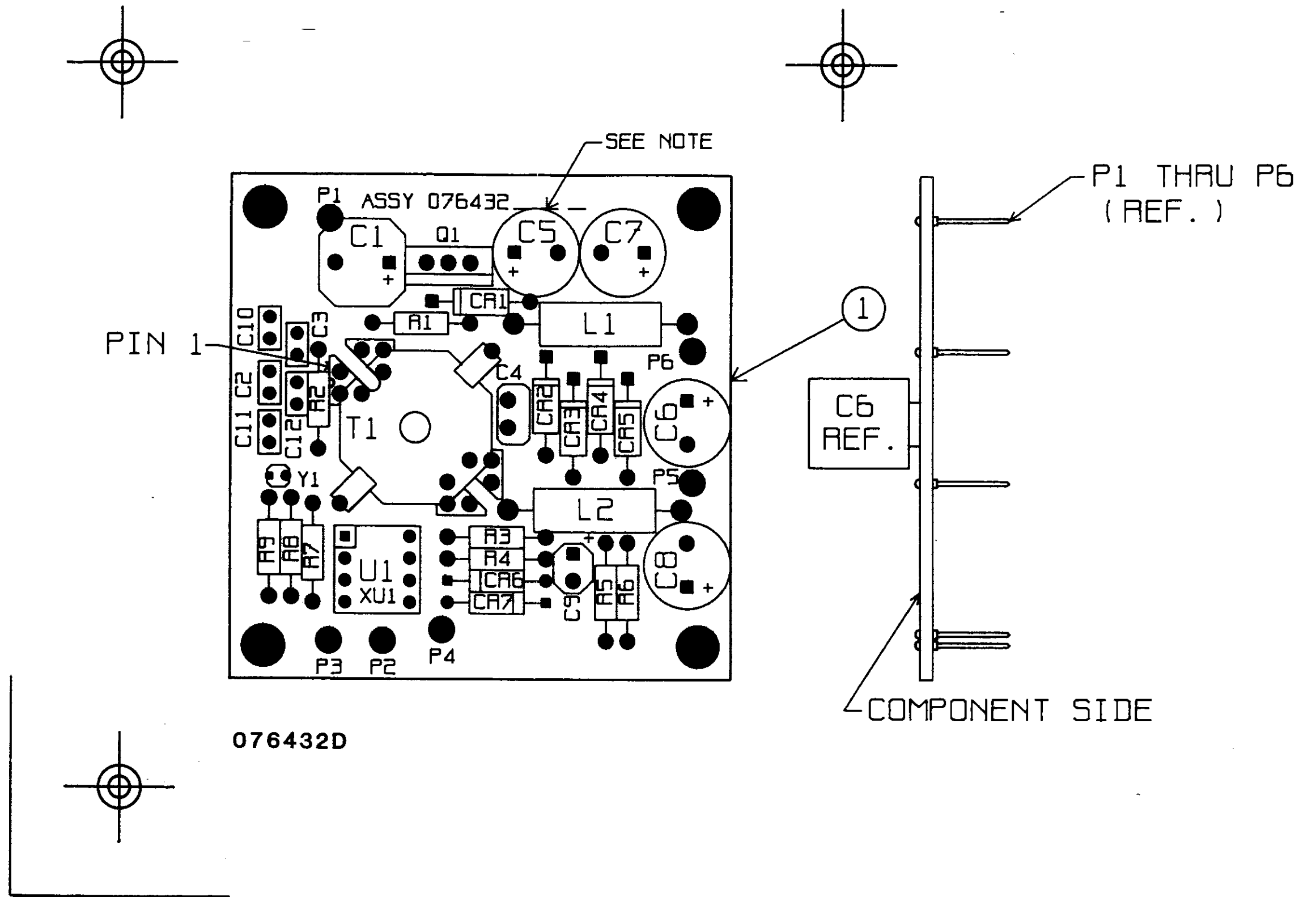

NOTE:

MARK FINAL ASSY PART NUMBER WITH 1/8 HIGH BLACK CHARACTERS.
 REFER TO MANUFACTURING ORDER FOR COMPLETE PART NUMBER

7-16 Figure 7-12. H.V. Supply Board, A4A1, Assembly Diagram.

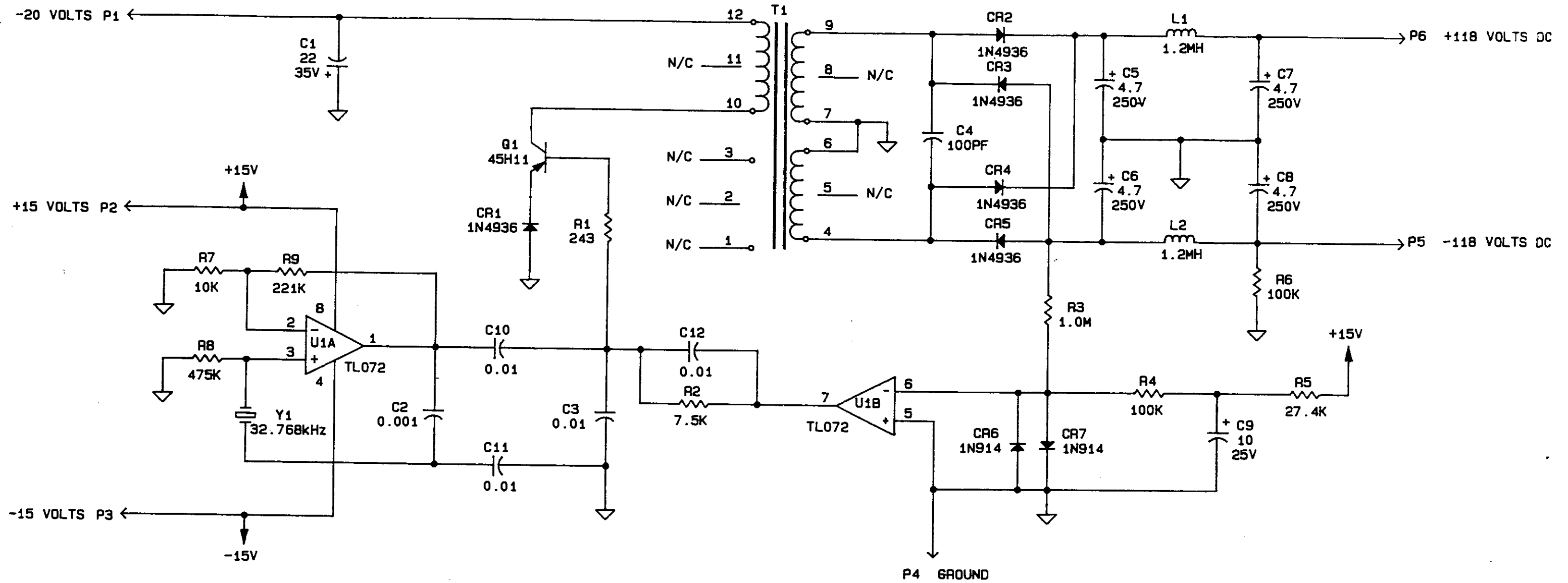

SCHMATIC, HIGH VOLTAGE POWER SUPPLY
83150907A, REV. A

NOTES:

1. CAPACITANCE VALUES IN UF, UNLESS OTHERWISE SPECIFIED.
2. RESISTANCE VALUES IN OHMS.
3. LAST NUMBERS USED:
C12 CR7 L2 P6 Q1
R9 T1 U1 Y1
4. HIGH VOLTAGE POWER SUPPLY PWB TO BE HOUSED IN A STEEL ENCLOSURE.
5. P1-6 CONNECT TO: J1-6 83150906A, SH. 6

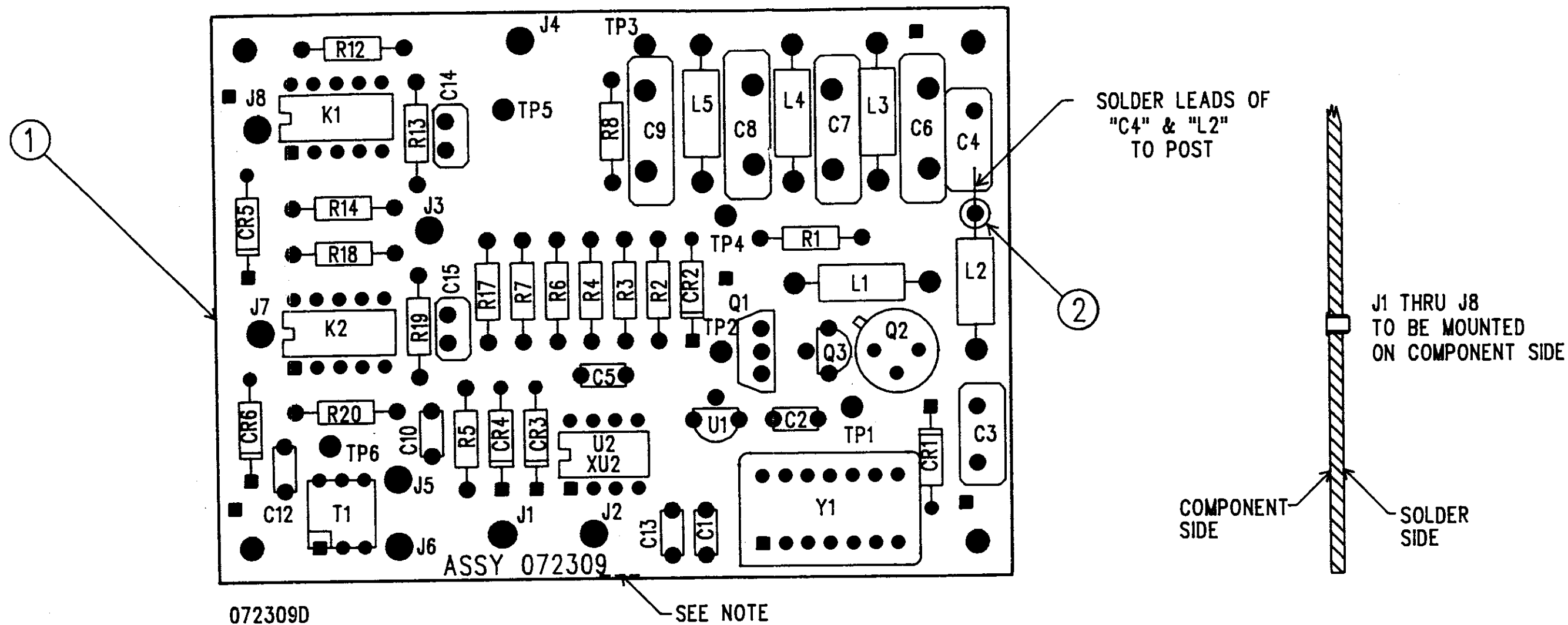

NOTE:

MARK FINAL ASSY PART NUMBER WITH 1/8 HIGH BLACK CHARACTERS.
REFER TO MANUFACTURING ORDER FOR COMPLETE PART NUMBER

7-18 Figure 7-14. Oscillator Board, A5A1, Assembly Diagram.

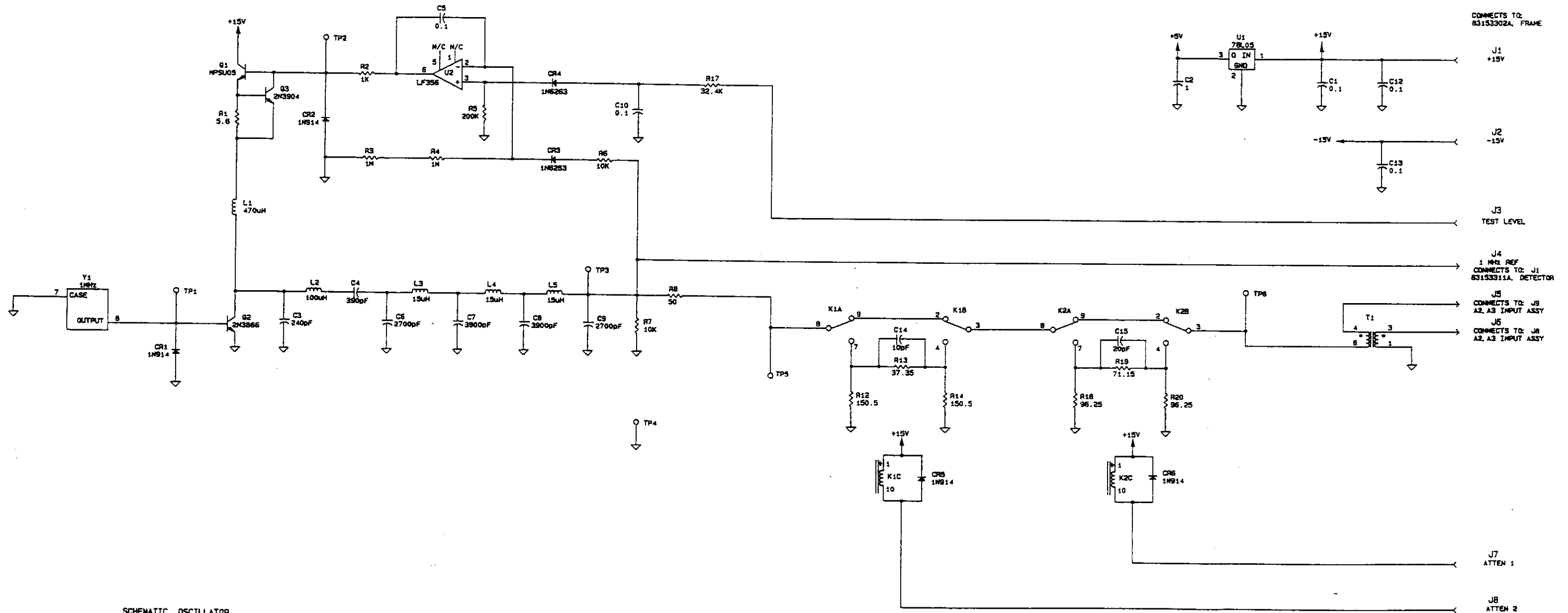

SCHEMATIC, OSCILLATOR
83153309A, REV. E

IC VOLTAGE CONNECTIONS					
REF. DESIG.	+5V	-5V	+15V	-15V	GND
	PIN NUMBERS				
U2			7	4	
Y1	14				7

- NOTES:
1. CAPACITANCE VALUES IN UF, UNLESS OTHERWISE SPECIFIED.
 2. RESISTANCE VALUES IN OHMS.
 3. LAST NUMBERS USED:
C15 CR6 R20 J8 T1
L5 K2 U2 Q3 TP6 Y1
 4. NUMBERS NOT USED:
C11 R9 R10 R11 R15 R16

Figure 7-15. Oscillator Board Schematic, A5A1. 7-19

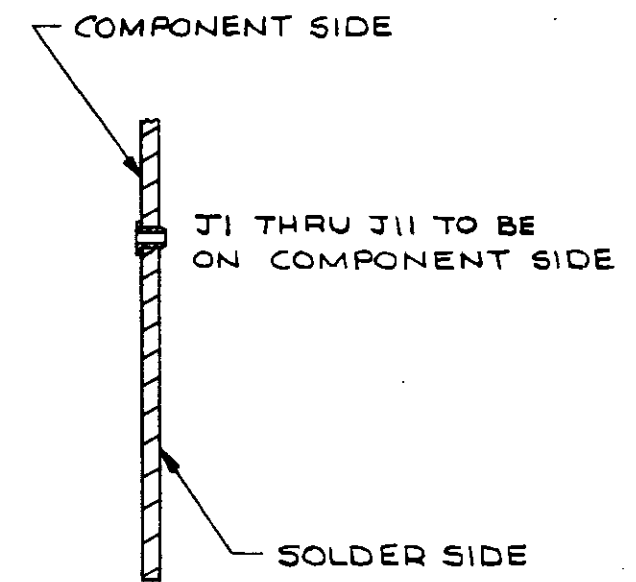
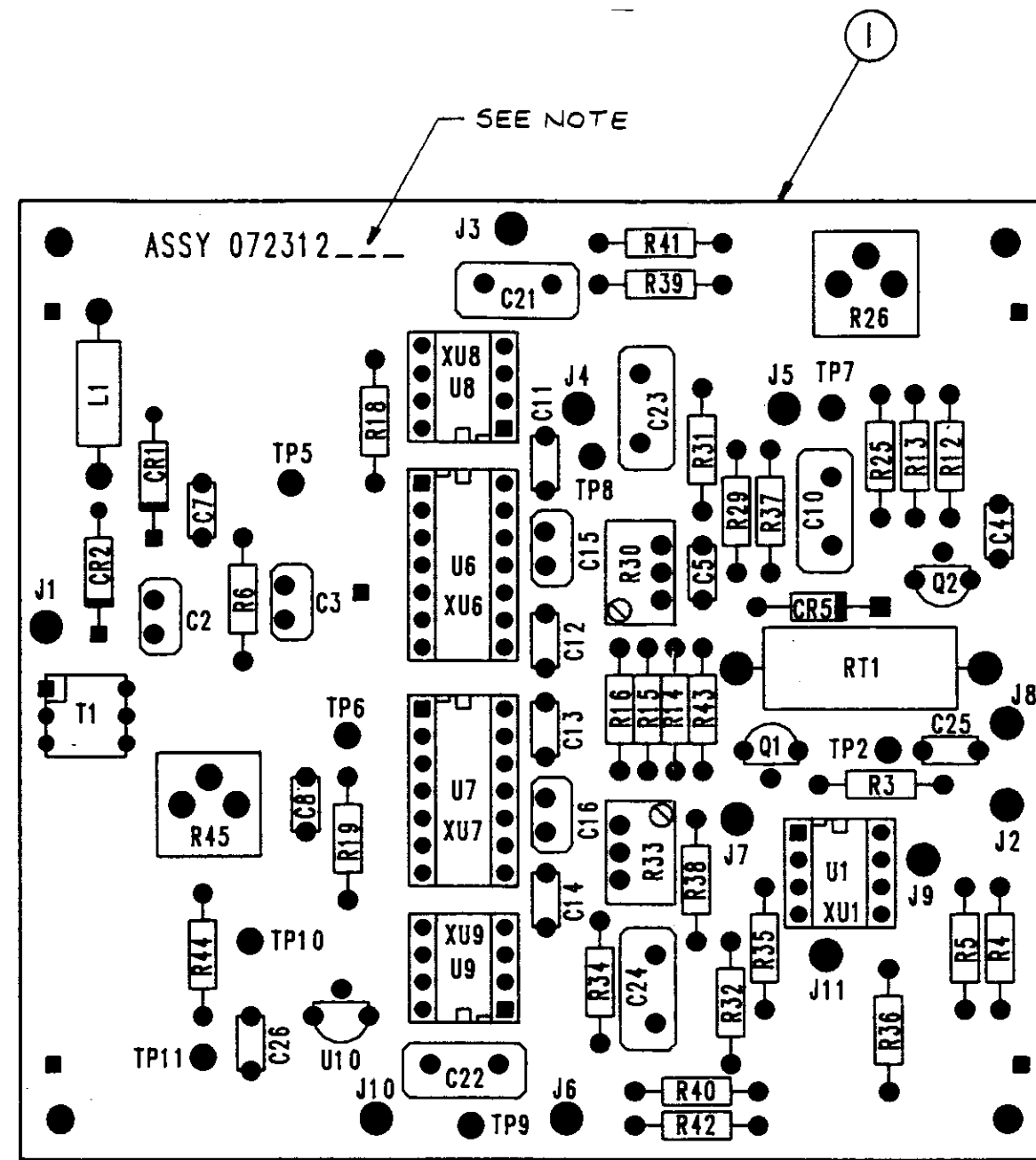

072312D

NOTE:

MARK FINAL ASSY PART NUMBER WITH 1/8 HIGH BLACK CHARACTERS.
REFER TO MANUFACTURING ORDER FOR COMPLETE PART NUMBER

7-20 Figure 7-16. Detector Board, A5A2, Assembly Diagram.

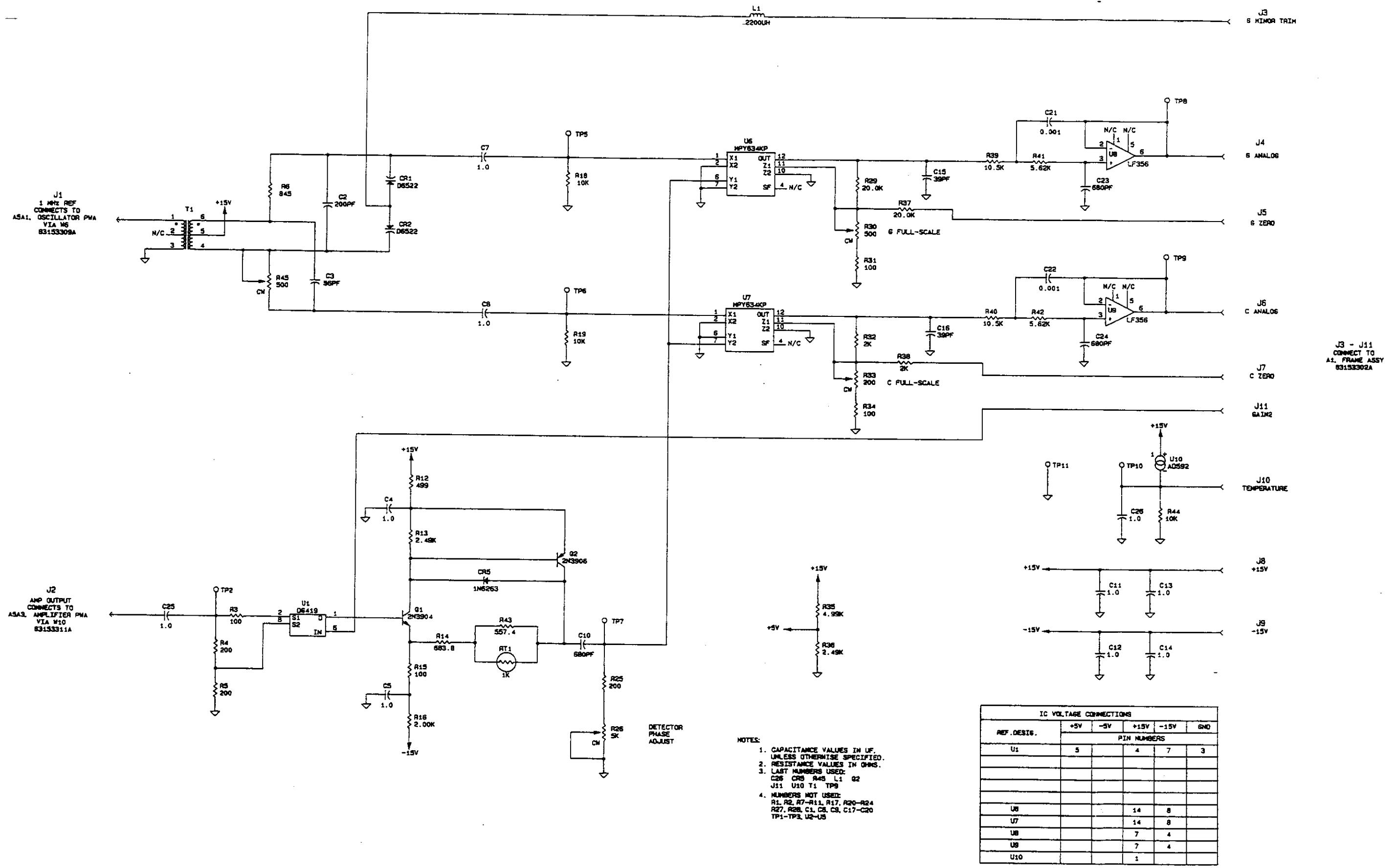

SCHEMATIC, DETECTOR
83153310A, REV F

Figure 7-17. Detector Board Schematic, A5A2. 7-21

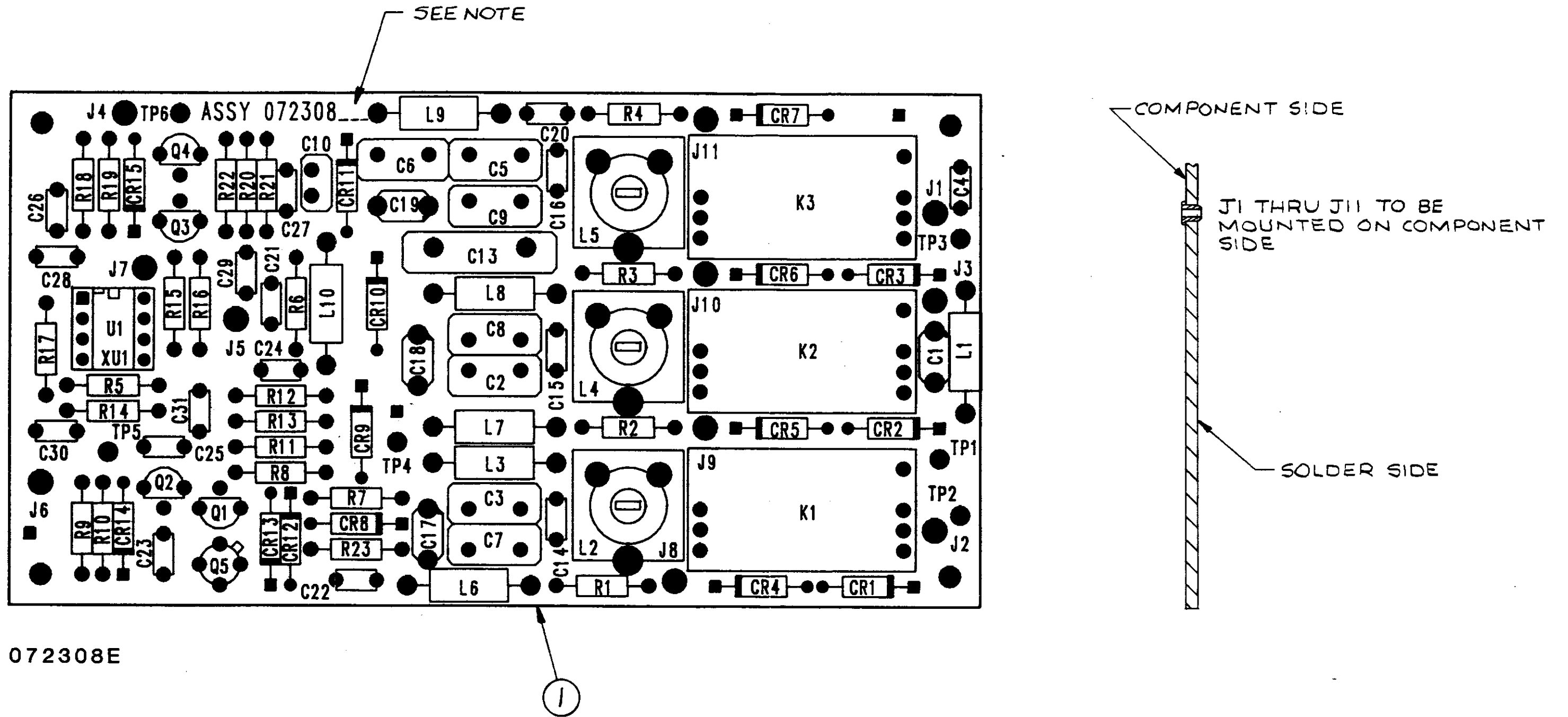

NOTE:

MARK FINAL ASSY PART NUMBER WITH 1/8 HIGH BLACK CHARACTERS.
 REFER TO MANUFACTURING ORDER FOR COMPLETE PART NUMBER

7-22 Figure 7-18. Amplifier Board, A5A3, Assembly Diagram.

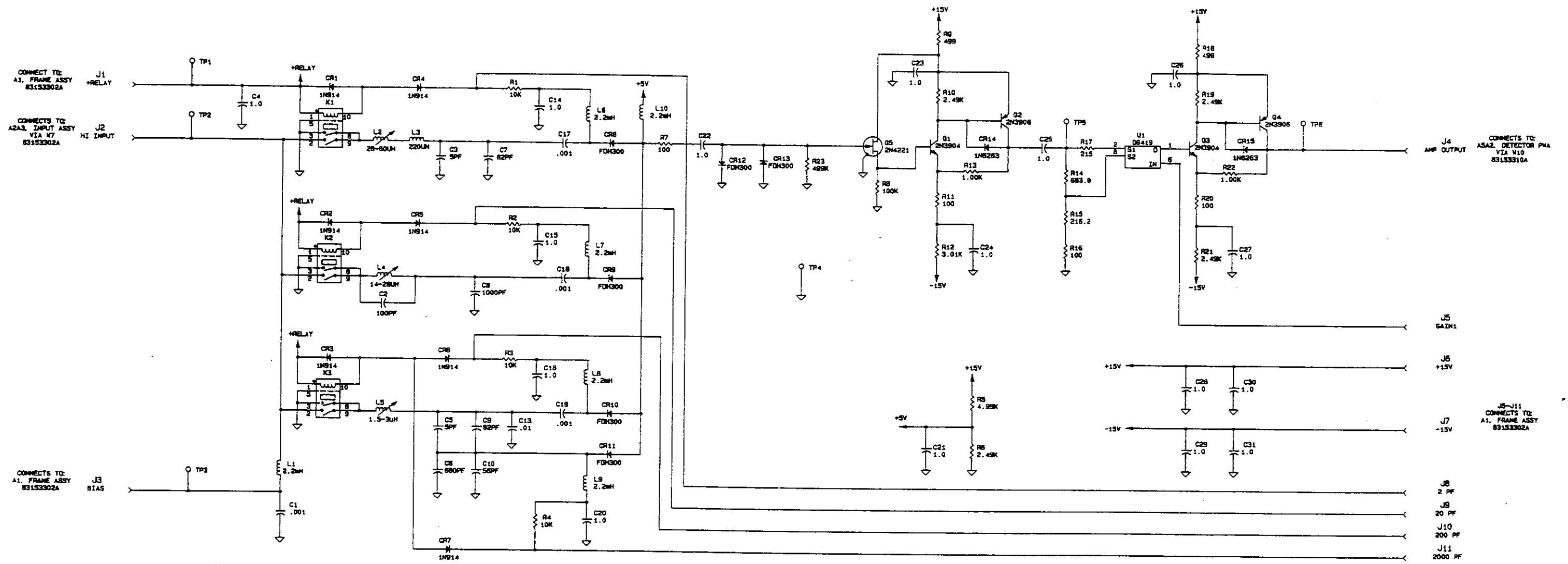

SCHEMATIC, AMPLIFIER
83153311A, REV D

REF. DESIG.	IC VOLTAGE CONNECTIONS				
	+5V	-5V	+15V	-15V	GND
U1	5	4	7	3	

NOTES:

1. CAPACITANCE VALUES IN UF, UNLESS OTHERWISE SPECIFIED.
2. RESISTANCE VALUES IN OHMS.
3. LAST NUMBERS USED:
R23 C31 L10 CR15 Q5
U1 K3 J11 TP6
4. NUMBERS NOT USED:
C11 C12

Figure 7-19. Amplifier Board Schematic, A5A3. 7-23

WARRANTY

Boonton Electronics Corporation (BEC) warrants its products to the original Purchaser to be free from defects in material and workmanship for a period of one year from date of shipment for instrument, and for one year from date of shipment for probes, power sensors and accessories. BEC further warrants that its instruments will perform within all current specifications under normal use and service for one year from date of shipment. These warranties do not cover active devices that have given normal service, sealed assemblies which have been opened or any item which has been repaired or altered without BEC's authorization.

BEC's warranties are limited to either the repair or replacement, at BEC's option, of any product found to be defective under the terms of these warranties.

There will be no charge for parts and labor during the warranty period. The Purchaser shall prepay shipping charges to BEC or its designated service facility and shall return the product in its original or an equivalent shipping container. BEC or its designated service facility shall pay shipping charges to return the product to the Purchaser. The Purchaser shall pay all shipping charges, duties and taxes if a product is returned to BEC from outside of the United States.

THE FOREGOING WARRANTIES ARE IN LIEU OF ALL OTHER WARRANTIES, EXPRESSED OR IMPLIED, INCLUDING, BUT NOT LIMITED TO, THE IMPLIED WARRANTIES OF MERCHANTABILITY AND FITNESS FOR A PARTICULAR PURPOSE. BEC shall not be liable to any incidental or consequential damages, as defined in Section 2-715 of the Uniform Commercial Code, in connection with the products covered by the foregoing warranties.

BOONTON
BOONTON ELECTRONICS CORPORATION
